

DEPARTMENT OF THE ARMY TECHNICAL MANUAL

OPERATOR, ORGANIZATIONAL, DS, GS,
AND DEPOT MAINTENANCE MANUAL
INCLUDING REPAIR PARTS AND SPECIAL TOOL LISTS
ANTENNA AS 1425/GRC'

This copy is a reprint which includes current
pages from Change 1.

HEADQUARTERS, DEPARTMENT OF THE ARMY

3 MARCH 1971

The following are general safety precautions that are not related to any specific procedure and, therefore, do not appear elsewhere in this publication. These are recommended precautions that personnel must understand and apply during many phases of operation and maintenance.

WARNING

Operator and maintenance personnel should be familiar with the safety requirements before attempting installation or operation of the equipment covered by this manual. Failure to follow requirements and observe safety precautions could result in injury or damage to the equipment.

WARNING

HIGH VOLTAGE

is used on this equipment.

DEATH ON CONTACT

may result if safety precautions are not observed.

WARNING

Operator and maintenance personnel should be familiar with the requirements of TB SIG 291 before attempting installation of the antenna.

WARNING

Performance of any field expedient repair creates a condition possibly dangerous to equipment and personnel. The equipment so repaired should be taken out of service as soon as possible for replacement of the defective parts.

WARNING

For the successful execution of methods of equipment destruction involving the use of demolition materials, all personnel should become thoroughly familiar with the pertinent provisions of FM 5-25.

CHANGE

NO. 2

HEADQUARTERS
DEPARTMENT OF THE ARMY
WASHINGTON, DC, 6 August 1984

**Operator, Organizational, DS, GS, and Depot
Maintenance Manual
ANTENNA AS-1425/GRC (NSN 5985-00-926-2593)**

TM 11-5985-335-15, 3 March 1971, is changed as follows:

1. Title of manual is changed as shown above. New or revised material is indicated by a vertical bar in the margin. Where an entire chapter, section, or illustration is added or revised, the vertical bar is placed opposite the identification number and title.
2. Remove old pages and insert new pages as indicated below.

<i>Remove pages</i>	<i>Insert pages</i>
None	A through D
3 through 22.....	3 through 22.2
24.1 and 24.2	24.1 and 24.2
25 through 30	25 through 30
37 and 38.....	37 and 38
41 and 42	41 and 42
A-1	A-1/(A-2 blank)
B-3 and B-4.....	B-3 and B-4
C-1 through C-4	C-1 through C-6
I-1, I-2 and I-3	I-1, I-2 and I-3/(I-4 blank)

3. File this change sheet in front of the publication.

By Order of the Secretary of the Army:

Official:

JOHN A. WICKHAM JR.
General, United States Army
Chief of Staff

ROBERT M. JOYCE
Major General, United States Army
The Adjutant General

DISTRIBUTION:

To be distributed in accordance with DA Form 12-51A-1, Operator's Maintenance requirement for AS-1425/GRC.



5

SAFETY STEPS TO FOLLOW IF SOMEONE IS THE VICTIM OF ELECTRICAL SHOCK

1

DO NOT TRY TO PULL OR GRAB THE INDIVIDUAL

2

IF POSSIBLE, TURN OFF THE ELECTRICAL POWER

3

IF YOU CANNOT TURN OFF THE ELECTRICAL POWER, PULL, PUSH, OR LIFT THE PERSON TO SAFETY USING A DRY WOODEN POLE OR A DRY ROPE OR SOME OTHER INSULATING MATERIAL

4

SEND FOR HELP AS SOON AS POSSIBLE

5

AFTER THE INJURED PERSON IS FREE OF CONTACT WITH THE SOURCE OF ELECTRICAL SHOCK, MOVE THE PERSON A SHORT DISTANCE AWAY AND IMMEDIATELY START ARTIFICIAL RESUSCITATION

WARNING

Adequate ventilation should be provided while using TRICHLOROTRIFLUOROETHANE. Prolonged breathing of vapor should be avoided. The solvent should not be used near heat or open flame; the products of decomposition are toxic and irritating. Since TRICHLOROTRIFLUOROETHANE dissolves natural oils, prolonged contact with skin should be avoided. When necessary, use gloves which the solvent cannot penetrate. If the solvent is taken internally, consult a physician immediately.

WARNING

Compressed air shall not be used for cleaning purposes except where reduced to less than 29 pounds per square inch (psi) and then only with effective chip guarding and personnel protective equipment. Do not use compressed air to dry parts when TRICHLOROTRIFLUOROETHANE has been used. Compressed air is dangerous and can cause serious bodily harm if protective means or methods are not observed to prevent chip or particle (of whatever size) from being blown into the eyes or unbroken skin of the operator or other personnel.

FIXED OPERATION WITH LONG RANGE ANTENNAS **WARNING**

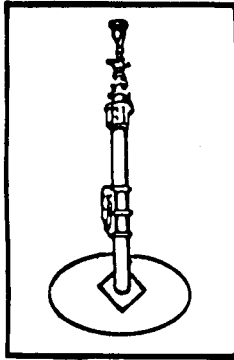

TELESCOPING ANTENNA
MAST

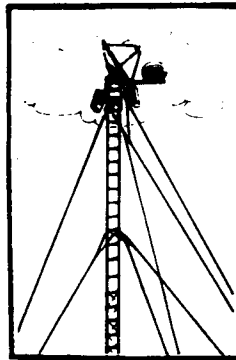

TYPICAL TOWER

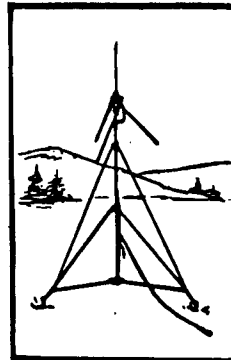

EXTENDED RANGE
ANTENNA



DOUBLET ANTENNA

NEVER ERECT THESE LONG RANGE ANTENNAS DIRECTLY UNDER POWER LINES.

If you must erect these long range antennas near powerlines, powerline poles or towers, or buildings with overhead powerline connections, never put the antenna closer than two times the antenna height from the base of the powerline, pole, tower or buildings.

NEVER ATTEMPT TO ERECT ANY LONG RANGE ANTENNA WITHOUT A FULL TEAM.

Before erecting any long range antenna, inspect all the parts making up the antenna kit. Do not erect the antenna if any parts are missing or damaged,

Do as much of the assembly work as possible on the ground.

When erecting the antenna, allow only team personnel in the erection area,

Make sure that the area for the anchors is firm. If the ground is marshy or sandy, get specific instructions from your crew chief or supervisor on how to reinforce the anchors,

When selecting locations for anchors, avoid traveled areas and roads. If you cannot avoid these areas, get specific instructions from your supervisor as to what clearance your guy wires and ropes must have over the traveled areas and road.

Clearly mark all guy wires and ropes with the warning flags or signs supplied by your unit. In an emergency, use strips of white cloth as warning streamers.

If you suspect that powerlines have made accidental contact with your antenna, stop operating, rope off the antenna area, and notify your superiors.

If the weather in your area can cause ice to form on your long range antenna and its guy wires and ropes, add extra guys to support the system. Rope off the area and post it with warning signs like "Beware of Falling Ice."

Do not try to erect any antenna during an electrical storm.

Keep a sharp eye on your anchors and guys. Check them daily and immediately before and after bad weather.

**OPERATOR, ORGANIZATIONAL, DS, GS, AND DEPOT MAINTENANCE
(INCLUDING REPAIR PARTS AND SPECIAL TOOL LISTS)**

ANTENNA AS-1425/GRC (NSN 5985-00-926-2593)

			Paragraph	Pages
CHAPTER	1.	INTRODUCTION		
Section	I.	General		
		Scope	1-1	7
		Consolidated Index of Army Publications and Blank Forms	1-2	7
		Maintenance Forms, Records, and Reports	1-3	7
		Reporting Errors and Recommending Improvements	1-3.1	7
		Reporting Equipment Improvement Recommendations (EIR)	1-3.2	10
		Administrative Storage	1-3.3	10
		Destruction of Army Electronics Materiel	1-3.4	10
	II.	Description and Data		
		Purpose and Use	1-4	10
		Tabulated Data	1-5	10.1
		Differences Between Configurations	1-5.1	10.1
		Components of Antenna AS-1425/GRC	1-6	10.1
		Description of Antenna AS-1425/GRC	1-7	10.2
		Description of Operating Accessories	1-8	11
		System Applications	1-9	11
CHAPTER	2.	INSTALLATION AND OPERATION		
Section	I.	Service Upon Receipt of Equipment		
		Unpacking the Equipment	2-1	14
		Checking Unpacked Equipment	2-2	16
		General Siting Considerations	2-3	16
		Plotting Profiles	2-4	17
	II.	Equipment Installation and Operation		
		Tools and Test Equipment Required for Installation	2-5	17
		Erection of Antenna	2-6	17
		Erection of Antenna with Mast and Antenna Extension Kits	2-6.1	20.1
		Antenna Adjustment Procedures	2-7	24
		Operation Under Unusual Climatic Conditions	2-8	25
CHAPTER	3.	OPERATOR/CREW AND ORGANIZATIONAL MAINTENANCE INSTRUCTIONS		
Section	I.	Operator/Crew Maintenance		
		Scope of Operator/Crew Maintenance	3-1	26
		Tools, Materials, and Test Equipment Required	3-2	26
		Operator/Crew Preventive Maintenance	3-3	26
		Operator/Crew Preventive Maintenance Checks and Services ...	3-3	28
		Operator/Crew Preventive Maintenance Checks and Services Chart	3-5	28
		Cleaning	3-6	28
		Operator's Troubleshooting	3-7	29
	II.	Organizational Maintenance		
		Organizational Preventive Maintenance Checks and Services ...	3-8	29
		Deleted	3-9	29
		Deleted	3-10	29
		Organizational Troubleshooting		
		Information 3-11	3-11	29
		Touchup Painting 3-12	3-12	29

		Paragraph	Pages
CHAPTER	4.	DIRECT AND GENERAL SUPPORT MAINTENANCE	
		Analysis of Operation	4-1 30
		General Maintenance Instructions	4-2 30
		Replacement of Components	4-3 30
		Removal and Replacement of Tilting Assembly	4-4 30
		Removal and Replacement of Feedhorn	4-5 31
		Removal and Replacement of Feedhorn Iris	4-6 31
		Removal and Replacement of Deicer Equipment	4-7 32
	5.	DEPOT MAINTENANCE	
Section	I.	General Information	
		General	5-1 33
		Maintenance Procedures	5-2 33
		Removal and Replacement of Reflector	5-3 33
		Disassembly and Reassembly of Tilting Assembly	5-4 34
	II.	Depot Overhaul Standards	
		Applicability of Depot Overhaul Standards	5-5 35
		Test Equipment Required	5-6 38
		Physical and Deicer Tests	5-7 38
		VSWR Test	5-8 39
CHAPTER	6.	SHIPMENT AND LIMITED STORAGE	
		Disassembly of Equipment	6-1 41
		Repackaging for Shipment or Limited Storage	6-2 41
APPENDIX	A.	REFERENCES	
			A-1
APPENDIX	B.	BASIC ISSUE ITEMS	
			B-1
APPENDIX	C.	MAINTENANCE ALLOCATION	
			C-1
APPENDIX	D.	ORGANIZATIONAL, DIRECT SUPPORT, GENERAL SUPPORT AND DEPOT MAINTENANCE REPAIR PARTS AND SPECIAL TOOLS LIST	
			D-1
INDEX.....			I-1

LIST OF ILLUSTRATIONS

<u>Figure</u>	<u>Title</u>	<u>Page</u>
1-1 (1)	Antenna AS-1425/GRC (Sheet 1 of 3)	8
1-1 (2)	Antenna AS-1425/GRC (Sheet 2 of 3)	8.1
1-1 (3)	Antenna AS-1425/GRC (Sheet 3 of 3)	9
1-2	Antenna AS-1425/GRC, Typical Systems Applications	13
2-1	Wooden Box, Typical Packaging Diagram	15
2-2	Typical Plotting Profiles	18
2-3	Attaching Antenna Backmount	20
2-4	Mounting Reflector Assembly (A).....	21
2-4.1	Mounting Reflector Assembly (B).....	22
2-5	Tightening Crosshandle Bolts (A).....	22.1
2-5.1	Antenna Mounting Secured (B)	22.2
2-6	Setting Antenna Polarization	23
2-7	Mounting Feedhorn to Reflector	24
2-8	Attaching Waveguide to Feedhorn	24.1
2-9	Reflectors and Guy Cable Arrangements for (a) Antenna, AS-1425/GRC, and (b) Antenna, AS-1425/GRC With Antenna Ex- tension Kit, MK-2228A/G (Used with Mast AB-621A/G and Mast Extension Kit, MK-2044/).....	24.2
2-10	Attaching Waveguide Clamp	24.3
4-1	Removal and Replacement of Deicer Equipment	32
5-1	Tilting Assembly, Exploded View	37
5-2	Reflector Dimensions	39
5-3	VSWR Test Setup Diagram	40

CHAPTER 1 INTRODUCTION

Section I. GENERAL

1-1. Scope

- a. This manual describes Antenna AS-1425/GRC (fig. 1-1) and covers its installation, operation and maintenance.
- b. Appendix A contains a list of publications applicable to this manual. Appendix B contains a list of components required for operation and organizational maintenance. Appendix C contains the assignment of maintenance functions and repair operations to be performed at the appropriate maintenance category.

NOTE

Basic manual is current as of 1 December 1970.

Change 2 is current as of 26 March 1984.

1-2. Consolidated Index of Army Publications and Blank Forms

Refer to the latest issue of DA Pam 310-1 to determine whether there are new editions, changes or additional publications pertaining to the equipment.

1-3. Maintenance Forms, Records and Reports

- a. *Reports of Maintenance and Unsatisfactory Equipment.* Department of the Army forms and procedures used for equipment maintenance will be those prescribed by DA Pam 738-750 as contained in Maintenance Management Update.
- b. *Report of Packaging and Handling Deficiencies.* Fill out and forward SF 364 (Report of Discrepancy (ROD)) as prescribed in AR 735-11-2/DLAR 4140.55/NAVMATINST 4355.73A/AFR 400-54/MCO 4430.3F.
- c. *Discrepancy in Shipment Report (DISREP)(SF 361).* Fill out and forward Discrepancy in Shipment Report (DISREP) (SF 361) as prescribed in AR 55-38/NAVSUPINST 4610.33C/AFR 75-18/MCO P4610.19D/DLAR 4500.15.

1-3.1. Reporting Errors and Recommending Improvements

You can help improve this manual. If you find any mistakes or if you know of a way to improve the procedures, please let us know. Mail your letter or DA Form 2028

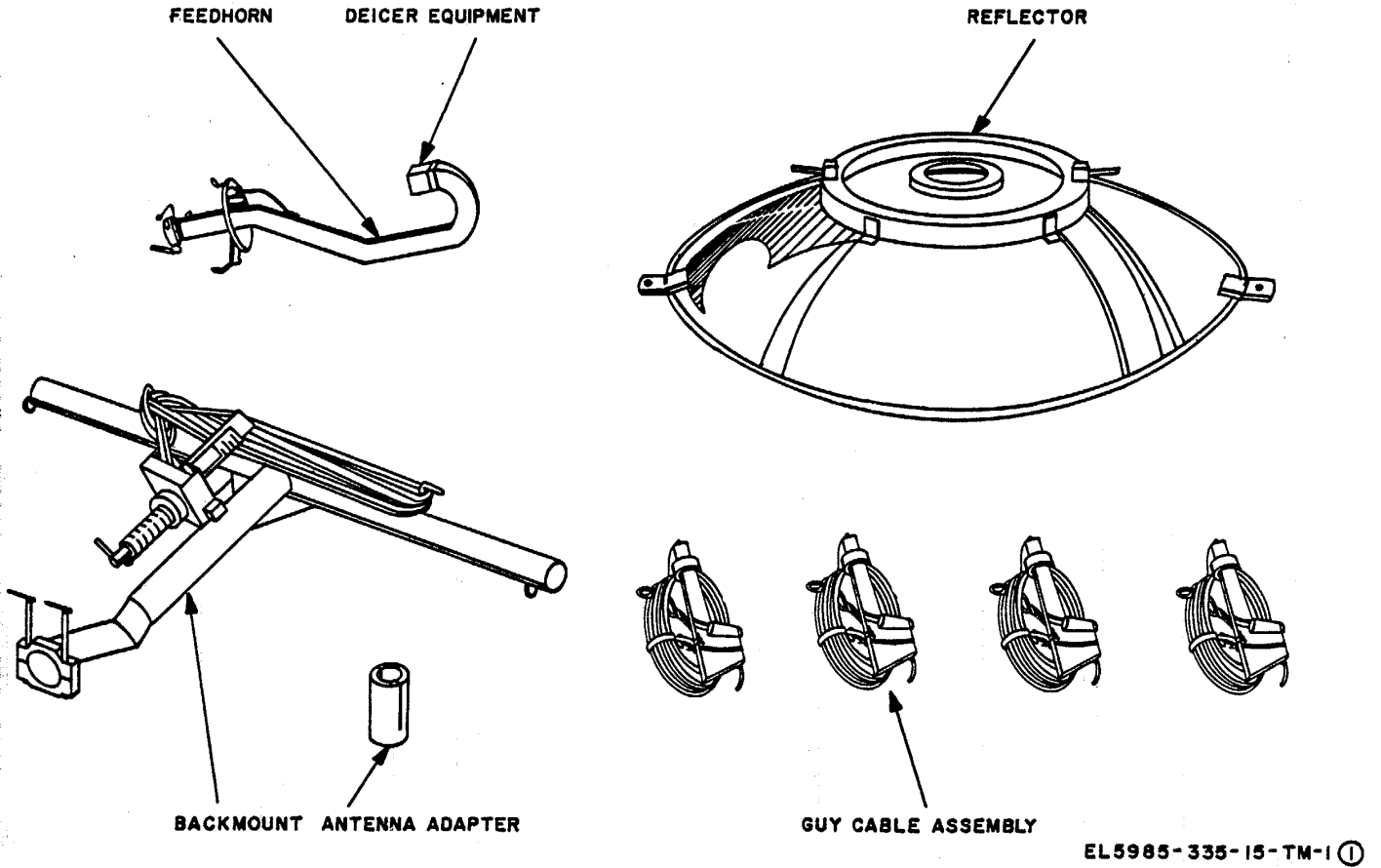
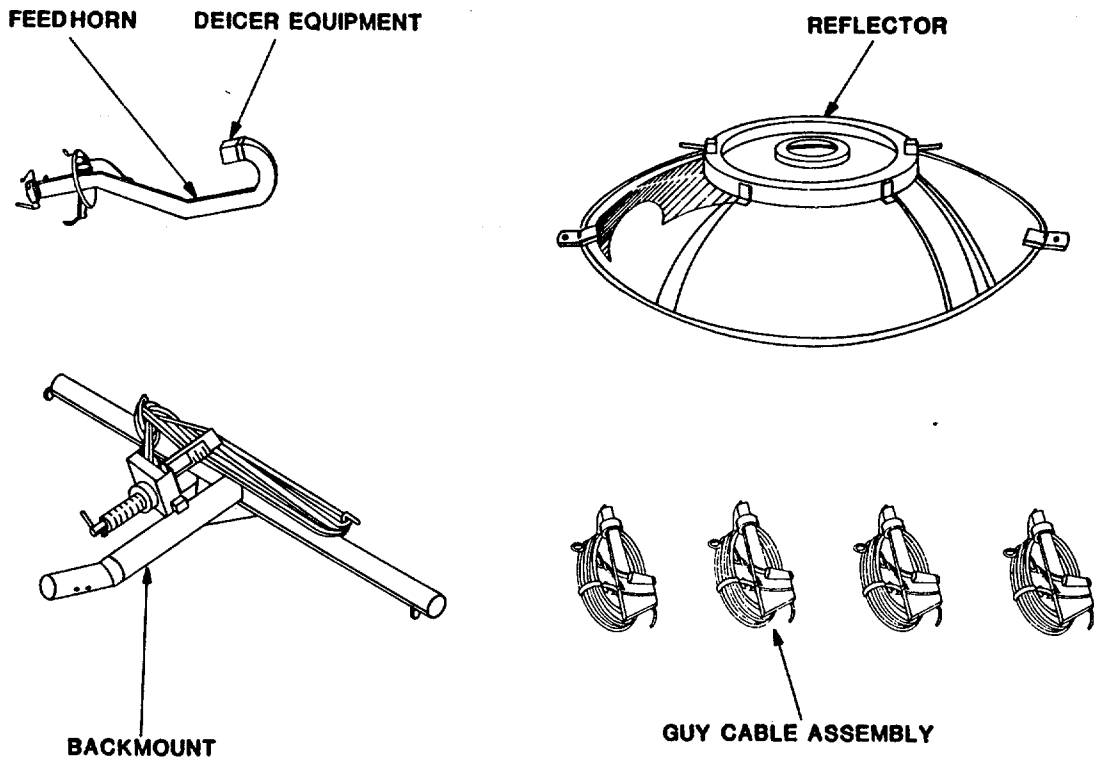

Figure 1-1⁽¹⁾. Antenna AS-1425/GRC (sheet 1 of 3).



EL6FS001

Figure 1-1⁽²⁾. Antenna AS-1425/GRC (sheet 2 of 3)

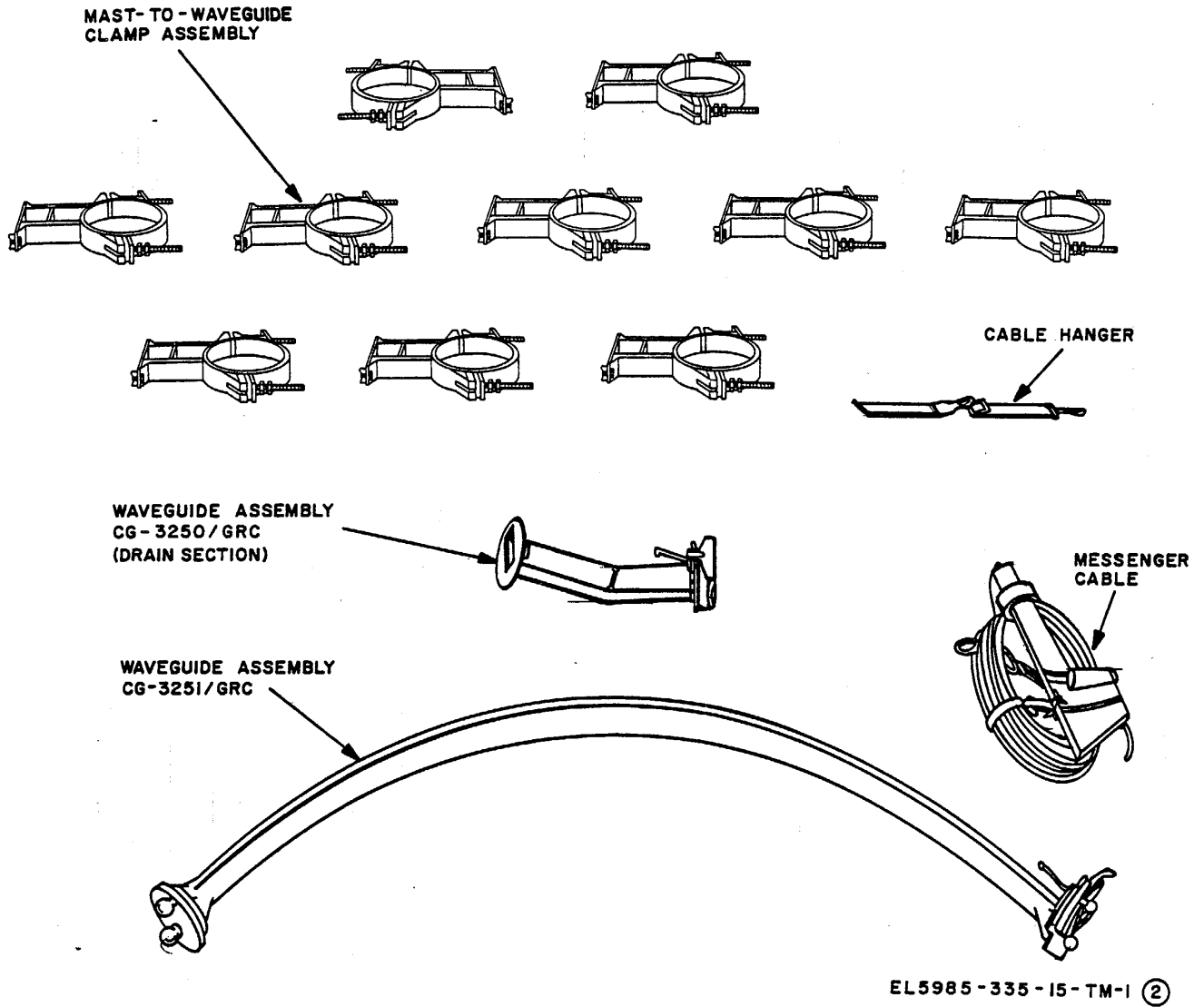

Figure 1-1⁽³⁾. Antenna AS-1425/GRC (sheet 3 of 3).

(Recommended Changes to Publications and Blank Forms) direct to: Commander, US Army Communications-Electronics Command and Fort Monmouth, ATTN: DRSEL-ME-MP, Fort Monmouth, New Jersey 07703. In either case, a reply will be furnished direct to you.

1-3.2. Reporting Equipment Improvement Recommendations (EIR)

If your Antenna AS-1425/GRC needs improvement, let us know. Send us an EIR. You, the user, are the only one who can tell us what you don't like about your equipment. Let us know why you don't like the design. Put it on an SF 368 (Quality Deficiency Report). Mail it to Commander, US Army Communications-Electronics Command and Fort Monmouth, ATTN: DRSEL-ME-MP, Fort Monmouth, New Jersey 07703. We'll send you a reply.

1-3.3. Administrative Storage

Administrative storage of equipment issued to and used by Army activities will have preventive maintenance performed in accordance with the PMCS charts before storing. When removing the equipment from administrative storage, the PMCS should be performed to assure operational readiness. Disassembly and repacking of equipment for shipment or limited storage are covered in chapter 6.

1-3.4. Destruction of Army Electronics Materiel

Destruction of Army electronics materiel to prevent enemy use shall be in accordance with TM 750-244-2.

Section II. DESCRIPTION AND DATA

1-4. Purpose and Use

Antenna AS-1425/GRC provides two-way line-of-sight radio communication in the super high-frequency (SHF) range of 4.4 to 5.0 gigahertz (GHz), and can be used to transmit and receive multichannel data with radio sets using pulse code modulation or frequency division multiplexing. The AS-1425/GRC is used primarily with Radio Set AN/GRC-147, and is usually mounted on top of a mast assembly such as Mast Assembly AB-621/G or AB-577/G.

NOTE

This listing is based on the original shipment by the contractor on Contract No. DAAB05-70-C-4408.

<u>Qty</u>	<u>Item</u>	<u>Dimensions (in.)</u>			<u>Weight</u>
		<u>Length</u>	<u>Depth</u>	<u>Width</u>	
1	Reflector assembly	55-1/2	10-1/4	55-1/2	
1	Horn assembly (feedhorn)	30	9-1/4	9-1/4	
1	Frame assembly (backmount)	54	10	30	
1	Housing assembly (tilting assembly)	15	4-1/8	4-7/8	
4	Guy cable assembly	(65 ft)			6
1	Antenna adapter (A)	2.84	5	2.84	
1	Waveguide Assembly CG-3250/GRC	12			1
6	Waveguide Assembly CG-3307/GRC	(15 ft)			20.7
2	Waveguide Assembly CG-3251/GRC	(4-1/2 ft)			6.2
8	Clamp assembly	8-3/4	3	11	5
1	Guy (messenger cable)	(75 ft)			7
15	Hanger assembly	13.5			0.6

b. Running spares of the AS-1425/GRC consist of two clamp assemblies.

1-7. Description of Antenna AS-1425/GRC

a. The AS-1425/GRC is a 4-1/2-foot diameter parabolic reflector type antenna consisting of the following components:

- (1) Reflector
- (2) Feedhorn (including deicer equipment)
- (3) Backmount
- (4) Tilting assembly
- (5) Antenna adapter (A)
- (6) Guy cables

b. The antenna reflector is supported by the backmount, which is usually mounted on a mast such as Mast Assembly AB-621/G or AB-577/G. The antenna feedhorn is mounted on the reflector in one of two positions, corresponding to two modes of polarization (horizontal or vertical). A dust cover is provided for the mouth of

the feedhorn. The vertical angle of radiation (elevation above or below the horizon) may be mechanically adjusted using the tilt tope of the tilting assembly. The antenna adapter (configuration A only) is provided for mounting the AS-1425/GRC on Mast Assembly AB-577/GRC. Four guy cable assemblies are provided to stabilize the AS-1425/GRC when mounted on a mast. An alternating current (ac) power connector is provided so that 115 volts, 60 Hertz (Hz) may be applied to the deicer equipment which is permanently mounted on the feedhorn. Radio frequency (rf) power to the feedhorn is applied through waveguide components which are selected according to the requirements of specific installations.

c. Each AS-1425/GRC antenna has two 4 1/2-foot sections of flexible Waveguide Assembly CG-3251/GRC, six 15-foot sections of flexible Waveguide Assembly CG-3307/ GRC, and one Waveguide Assembly CG-3250/GRC (a drain section). The 15-foot sections are stowed on special reels, and are not shown in figure 1-1. The waveguides are secured to the mast (when mast mounted) by the mast-to-waveguide clamp assemblies. One guy (messenger cable) is used with the cable hangers assemblies to support the waveguide run to the shelter in which the associated radio set is usually installed.

1-8. Description of Operating Accessories

Operating accessories of the AS-1425/GRC are necessary for installation, operation, or maintenance and normally consist of the following:

- a. A mast, such as Mast Assemblies AB-621/G or AB-577/G, is required if the AS-1425/GRC is to be elevated to clear obstructions, powerlines, etc.
- b. A level assembly and spanner wrench are required for leveling the mast assembly and for adjusting the position of the antenna (in azimuth) on the mast assembly (TM 11-5820-568-12) .

NOTE

Special tools for other mast assemblies are listed in the technical manual for the specific mast assembly or associated radio set.

1-9. System Applications

Antenna AS-1425/GRC provides the transmitting and receiving antenna elements of a radio communications network. When used for direct line-of-sight communications, an AS-1425/GRC is required at each of the two terminals. When a relay station is used, four AS-1425/GRC antennas are required--one at each terminal and two at the relay station. In each of these configurations, the AS-1425/GRC may be used with

appropriate radio sets and multiplexing equipment to provide reception and transmission of frequency division multiplex or pulse code modulated data.

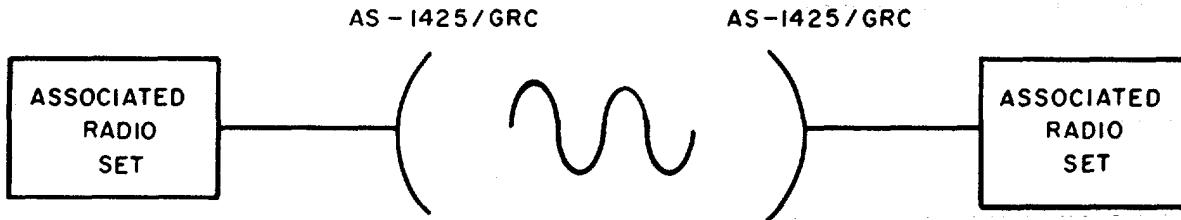

A. TYPICAL TWO WAY COMMUNICATION CONFIGURATION.

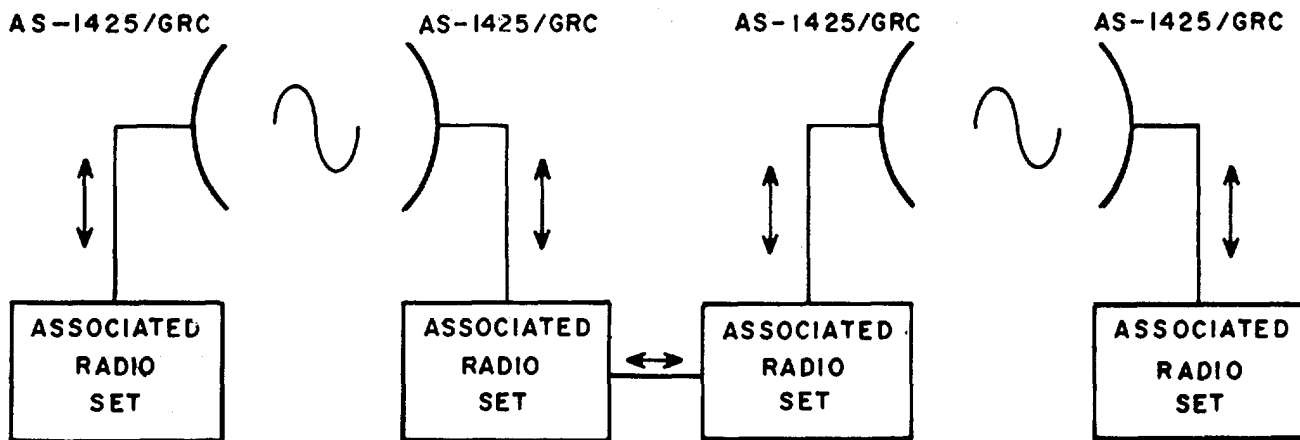

B. TYPICAL RADIO RELAY CONFIGURATION

EL 5985 - 335 - 15 - TM-13

Figure 1-2. Antenna AS-1425/GRC, typical system applications

CHAPTER 2
INSTALLATION AND OPERATION

Section I. SERVICE UPON RECEIPT OF EQUIPMENT

2-1. Unpacking the Equipment

a. *Packaging Data.* When packed for shipment, the components and accessories of Antenna AS-1425/GRC are usually placed in a wooden box and four cartons. A typical packaging diagram for a wooden box is shown in figure 2-1.

b. *Packing Dimensions.* The dimensions, volume, weight and contents of the packed containers of the AS-1425/GRC are given below in the chart:

Container No.	Dimensions (in.)	Volume (cu ft)	Weight (lb)	Contents
Box 1	58x58x26.5	51.6	258	Reflector Backmount Feedhorn Antenna Adapter (A only) Guy cable assemblies (yellow coded) (4) Guy (messenger cable) Clamp assemblies (10) Technical manual
Cartons:				
2	30x30x10	5.2	51	Waveguide Assembly CG-3307/GRC (2)
3	30x30x10	5.2	51	Waveguide Assembly CG-3307/GRC (2)
4	30x30x10	5.2	51	Waveguide Assembly CG-3307/GRC (2)
5	30x30x10	5.2	51	Waveguide Assembly CG-3250/GRC Waveguide Assembly CG-3251/GRC (2) Hanger assemblies (15)

c. *Removing Contents of Wooden Box.* Remove the AS-1425/GRC components from the wooden box using the procedure outlined in (1) through (7) below:

- (1) Before unpacking, place the wooden box as near as possible to the mast location.

CAUTION

Do not thrust any tools into the interior of the wooden box or any of its cartons.

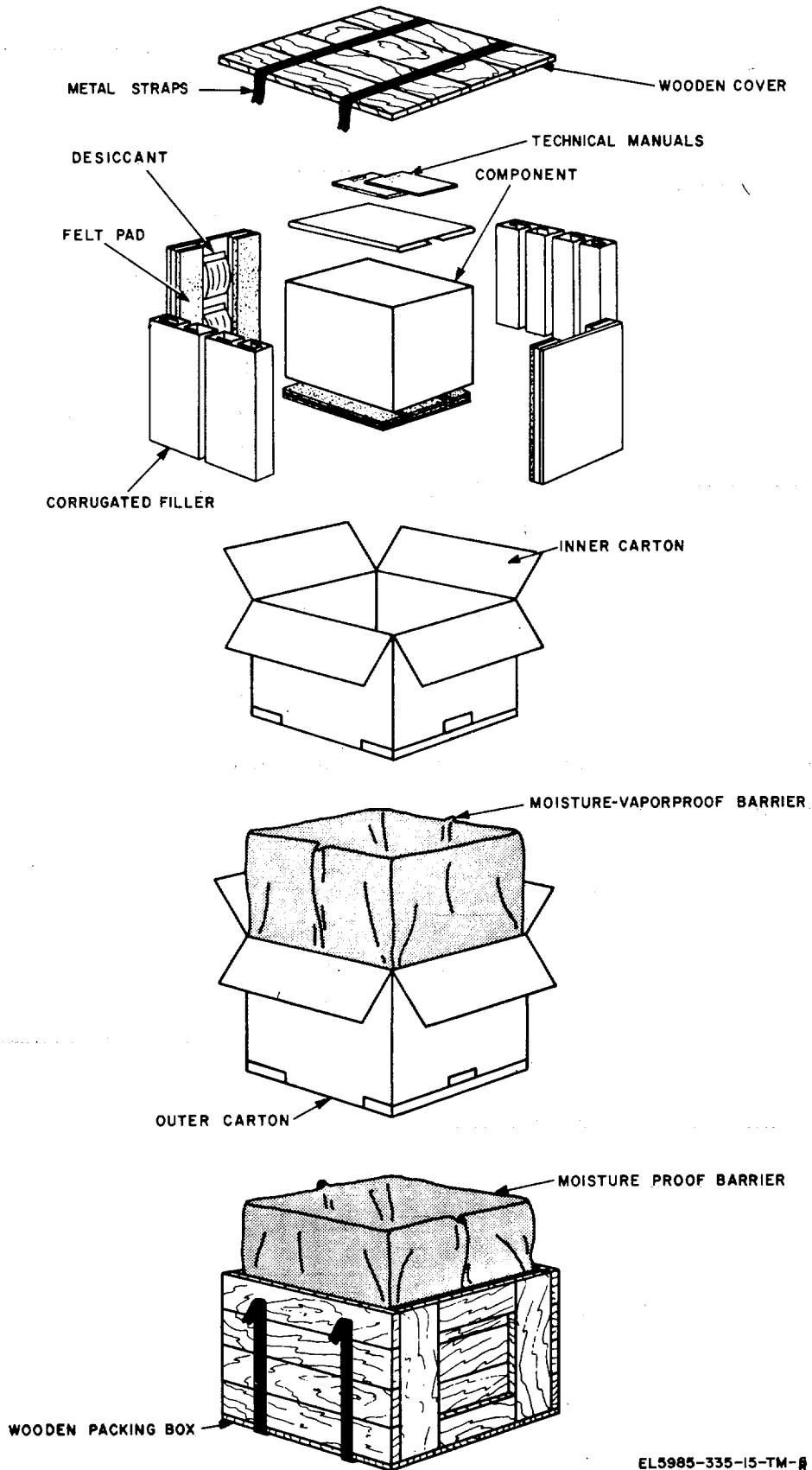

EL5985-335-15-TM-8

Figure 2-1. Wooden box, typical packaging diagram.

(2) Cut the metal straps around the wooden box and fold them back out of the way.

Caution: Do not attempt to pry off the top or any side as damage to the equipment may occur.

Note: Save all the packaging material except the desiccant (dehydrating agent) for repacking. The wooden box is reusable.

(3) Remove the nails from the top and sides of the wooden box with a nail puller. Remove the top and all sides.

(4) Open the sealed moisture proof barrier.

(5) Cut through and along the upper edges of the outer carton along three dimensions. Open the flaps on the top of the outer carton.

(6) Open the sealed moisture-vaporproof barrier, and repeat step (5) for the inner carton containing the equipment.

(7) Remove the technical manual and all felt pads, corrugated filler, or other packaging material from the inner carton.

2-2. Checking Unpacked Equipment

a. Inspect the equipment for damage that may have been incurred during shipment. Report damages in accordance with paragraph 1-3.

b. Check to see that the equipment is complete as listed on the packing list. If a packing list is not available, check the equipment against the basic issue item list (appx B). Report all discrepancies in accordance with DA Pam 738-750. Shortage of a minor assembly or part that does not affect proper functioning of the equipment should not prevent use of the equipment.

c. If the equipment has been used or reconditioned, check to see whether it has been changed by a modification work order (MWO). If this equipment has been modified, the MWO number will appear on the reflector near the nomenclature plate. Check to see whether the MWO number (if any) and the appropriate notations concerning the modification have been entered in the equipment manual.

Note: Current MWO's applicable to the equipment are listed in DA Pam 310-1.

2-3. General Siting Considerations

The location for operation of Antenna AS-1425/GRC depends on the tactical situation, terrain, proximity and direction of enemy positions, and other local considerations. When selecting a site, consider the following requirements;

a. The desirability of unobstructed line-of-sight antenna positioning with respect to all available and active communication sites.

b. A supporting ground surface that is sufficiently firm, level, and well drained.

- c. Avoid locating the antenna near electrical interference sources such as radar sets and power transmission lines.

2-4. Plotting Profiles

To determine that a line-of-sight path exists before attempting an installation, draw a profile map of the terrain between the two sites (fig. 2-2). Nonlinear graph paper may be used for plotting profiles from terrain maps as follows:

- a. Determine the scales to be used for the distances involved.
- b. Draw a line between the two proposed sites (A or D, fig. 2-2). Convert the length of this line to distance.
- c. Determine the total elevation of each site, including antenna height above ground (40 feet in the examples of fig. 2-2). Draw a straight line between two points. Note the lowest point along the line.
- d. Draw a complete profile of the terrain between the two sites. Pick up the high and low points along the line. Plot these points, then join them. All points that are above the straight line on the graph (C or E, fig. 2-2) represent intervening obstructions.
- e. For best communications, use a path such as path 4 (F, fig. 2-2).

Section II. EQUIPMENT INSTALLATION AND OPERATION

2-5. Tools and Test Equipment Required for Installation

Tool Kit, Electronic Equipment TK-101/G (NSN 5180-00-064-4178) and Multimeter AN/URM-105 (NSN 6625-00-581-2036) are the only tools and test equipment required. For additional tools, refer to the technical manual for the associated radio set or mast assembly with which the AS-1425/GRC is to be used.

2-6. Erection of Antenna

WARNING

During installation of this equipment, conform to all safety requirements set forth in TB SIG 291. Do not install antenna at a distance of less than twice the height of the mast from power lines. Do not attempt antenna installation if the windspeed exceeds 25 miles per hour (21.7 knots).

The AS-1425/GRC (configuration A) may be mounted on any adequate mast assembly by using a special mast adapter. (The mast must be properly sited in accordance with paragraph 2-3.) Install each antenna using the procedure outlined in a through m below.

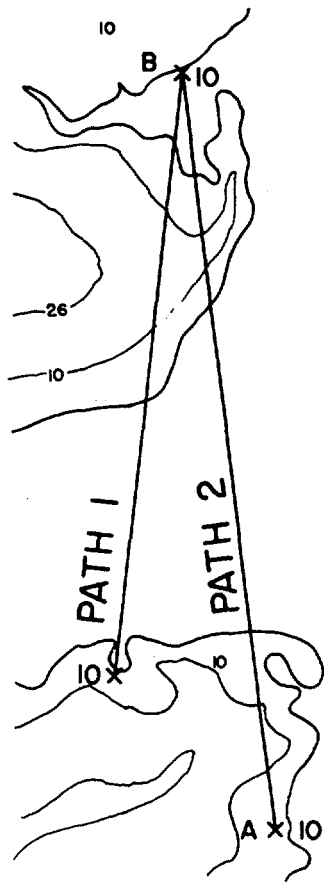

A

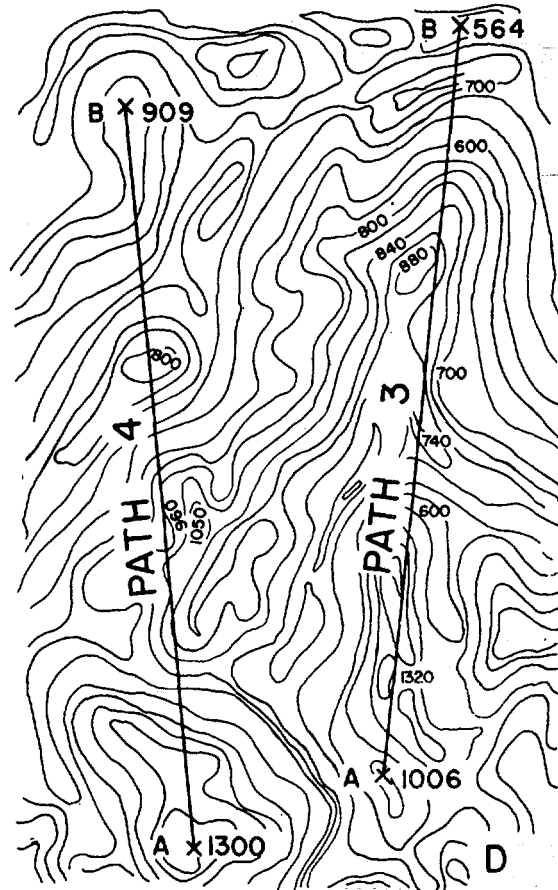

D

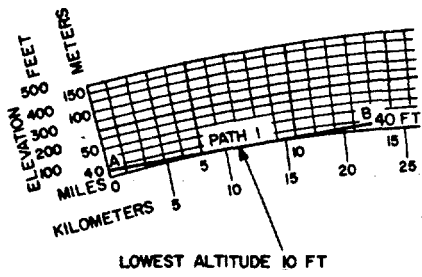

B

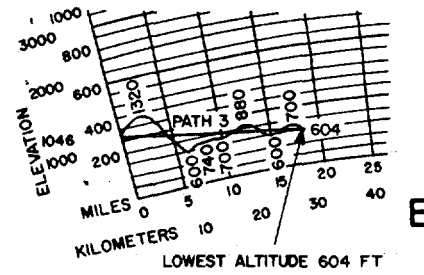

E

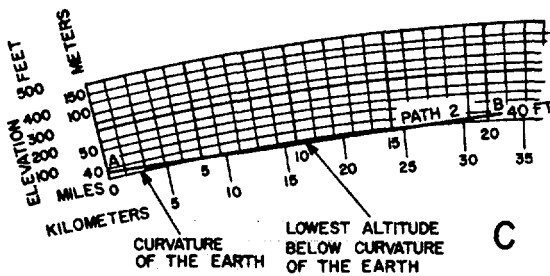

C

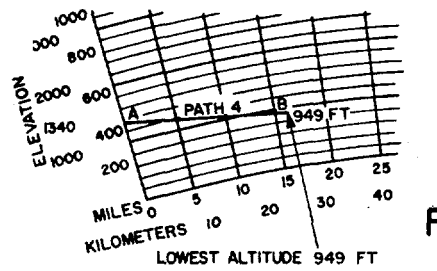

F

EL5985-335-15-TM-10

Figure 2-2. Typical plotting profiles

- a. Unload the wooden box and the cartons containing the AS-1425/GRC near the mast.
- b. Attach the antenna backmount to the antenna reflector with the pins provided in the reflector assembly as illustrated in figure 2-3.
- c. Using two people, lift the antenna reflector assembly and slide it onto the mast cap as shown in figure 2-4, and make sure that the index marks on the two units match.
- d. Tighten the crosshandle bolts on the antenna backmount as illustrated in figure 2-5.
- e. Secure antenna to mast cap by inserting quick release pin through holes in antenna frame and mast cap until head of pin is against frame tube.
- f. Insert the feedhorn through the circular opening in the antenna reflector. Turn the feedhorn assembly so that the index arrow on the feedhorn mounting plate matches the appropriate polarization index arrow on the reflector, as shown in figure 2-6.
- g. Mount the feedhorn to the reflector with the four wingbolts as shown in figure 2-7. Stow the feedhorn flange cover plate, using the stowage bolt holes near the flange.
- h. If use of the deicer equipment is anticipated, connect ac power (115 volts, 60 Hz) at the power connector shown covered in figure 2-7 on the feedhorn assembly.

CAUTION

There is a possibility of antenna failure due to a lack of proper waterproofing and RF leakage. This is caused by failure of Neoprene Rubber "O" rings to remain seated in the grooves of the antenna waveguide joints during installation. The retention of the "O" rings can be accomplished by applying silicon adhesive to the rings prior to assembling the waveguide sections (ADHESIVE SEALANT, RTV, GENERAL PURPOSE, TYPE I, CLEAR (NSN 8040-00-833-9563)).

- i. Clamp one 4 1/2-foot section of CG-3251/GRC flexible waveguide to the feedhorn (fig. 2-8). A clamp is provided on the waveguide section. Stow the flexible waveguide cover in the clip provided on the waveguide.
- j. Attach the four yellow-coded guy cables and the messenger cable to the eyebolts on the antenna backmount. Figure 2-9 shows a typical guy cable arrangement for the antenna.
- k. Clamp one 15-foot section of CG-3307/GRC flexible waveguide to the 4 1/2-foot section of CG-3251/GRC flexible waveguide. The clamp is provided on the 15-foot waveguide section.

CAUTION

Make sure that the guy cables are manned when raising the AS-1425/GRC.

- l. Attach waveguide clamps (fig. 2-10) and additional waveguide sections as the mast is being raised.
- m. Complete the waveguide run (and power cable run, if used) to the shelter, using cable hanger assemblies as required with the messenger cable.

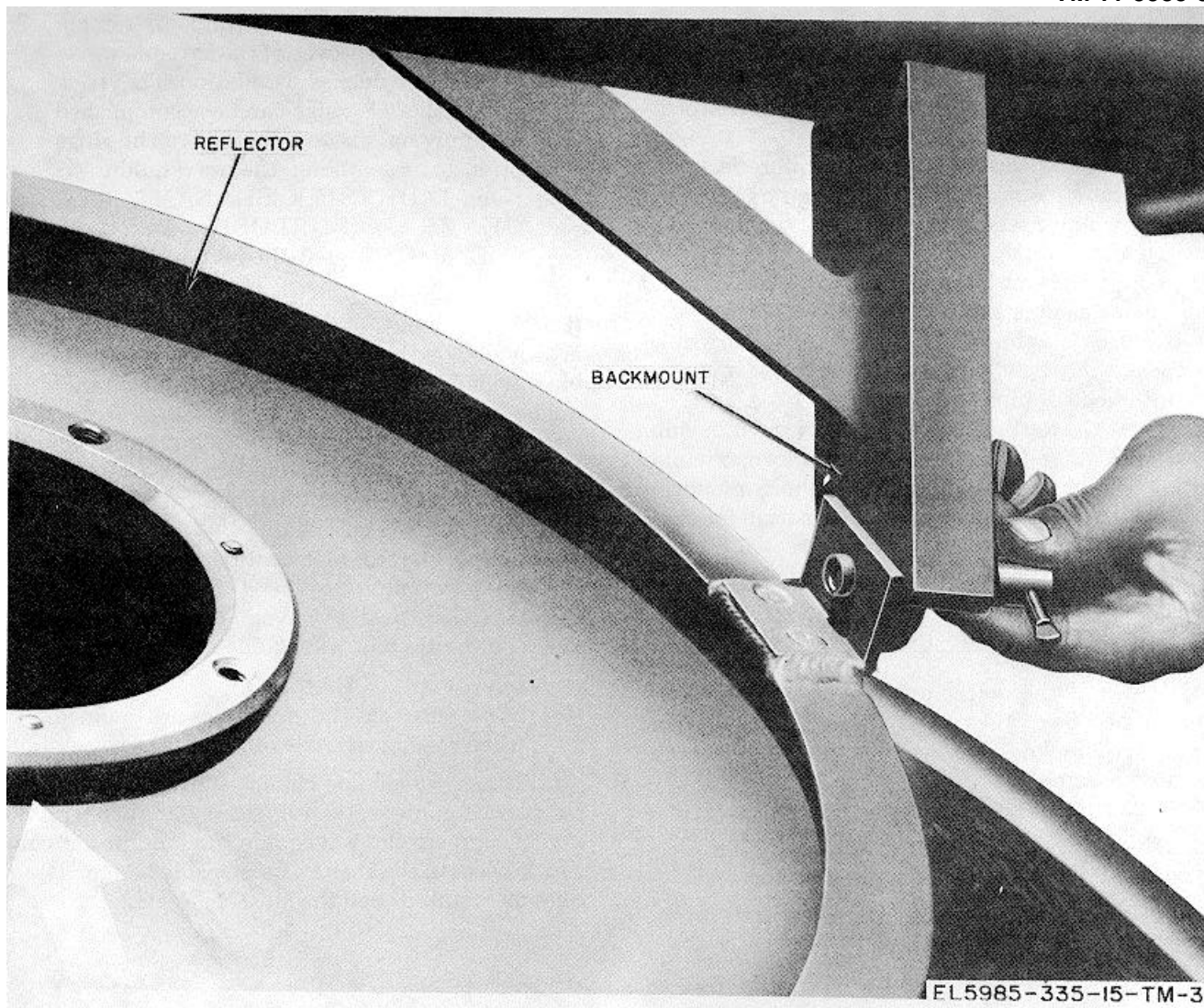

Figure 2-3. Attaching antenna backmount.

2-6.1. Erection Procedure of Antenna AS-1425/GRC with Kit, Antenna Extension MK-2228A/G (fig 2-9(a))

If the AS-1425/GRC antenna is to be raised to 100 ft, using Mast AB-621A/G with Extension Kit MK-2044/G, Antenna Extension Kit MK-2228A/G must be used. Because only two out of three antennas and masts provided with the AN/TRC-138 radio set are used at the same time, parts are to be utilized from the third unused mast and antenna. Needed are three waveguides, CG-3307/GRC (15 ft, 0 in), and five waveguide clamps from the third unused AS-1425/GRC antenna and four tensioners from the third unused AB-621A/G mast. The following lists the components needed to raise Antenna AS-1425/GRC to 100 ft.

<u>QTY</u>	<u>ITEM</u>	<u>WEIGHT (lbs.)</u>
4	Cable Assembly	2
1	Elevation Control Rope	1
4	Screw Anchor	6
8	Waveguide Clamp	5
2	Shackle	1 (Total)
3	Waveguide	
4	Tensioners	

WARNING

During installation of this equipment, conform to all safety requirements set forth in TB SIG 291. Do not install antenna at a distance of less than twice the height of the mast from power lines. Do not attempt antenna installation if the windspeed exceeds 25 miles per hour (21.7 knots).

The AS-1425/GRC may be mounted on any adequate mast assembly by using a special mast adapter. (The mast must be properly sited in accordance with para 2-3). Install each antenna by following the procedure outlined in a through l below:

- a. Unload the wooden box and cartons containing Antenna AS-1425/GRC and Kit, Antenna Extension MK-2228A/G near the mast. Also unload the three Waveguides CG-3307/GRC (15 ft, 0 in.) and five waveguide clamps from the wooden box and cartons containing the third unused AS-1425/GRC antenna. Finally, remove four tensioners from the guy assemblies of the third unused AB-621A/G mast.
- b. Attach the antenna backmount to the antenna reflector with the pins provided in the reflector assembly as illustrated in figure 2-3.
- c. Using two people, lift the antenna reflector assembly and slide it onto the mast cap as shown in figure 2-4, and make sure that the index marks on the two units match.

- d. Tighten the crosshandle bolts on the antenna backmount as illustrated in figure 2-5.
- e. Insert the feedhorn through the circular opening in the antenna reflector. Turn the feedhorn assembly so that the index arrow on the feedhorn mounting plate matches the appropriate polarization index arrow on the reflector, as shown in figure 2-6.
- f. Mount the feedhorn to the reflector with the four wingbolts as shown in figure 2-7. Stow the feedhorn flange cover plate, using the stowage bolt holes near the flange.
- g. If use of the deicer equipment is anticipated, connect ac power (115 volts, 60 Hz) at the power connector (shown covered in fig. 2-7) on the feedhorn assembly.
- h. Clamp one 4 1/2-foot section of CG-3251/GRC flexible waveguide to the feedhorn (fig. 2-8). A clamp is provided on the waveguide section. Stow the flexible waveguide cover in the clip provided on the waveguide.
- i. Attach shackles to backmount eyebolts. Attach four purple-coded cables to shackles. Attach the four tensioners to the free end of the cable assemblies. Figure 2-6 shows the guy cable arrangement for the antenna with the antenna extension kit.
- j. Clamp one 15-foot section of CG-3307/GRC flexible waveguide to the 4 1/2-foot section of CG-3251/GRC flexible waveguide. The clamp is provided on the 15-foot waveguide section.

CAUTION

Make sure that the guy cables are manned when raising the AS-1425/GRC.

- k. Attach waveguide clamps (fig. 2-10) and additional waveguide sections as the mast is being raised.
- l. Complete the waveguide run (and power cable run, if used) to the shelter, using cable hanger assemblies as required with the messenger cable.

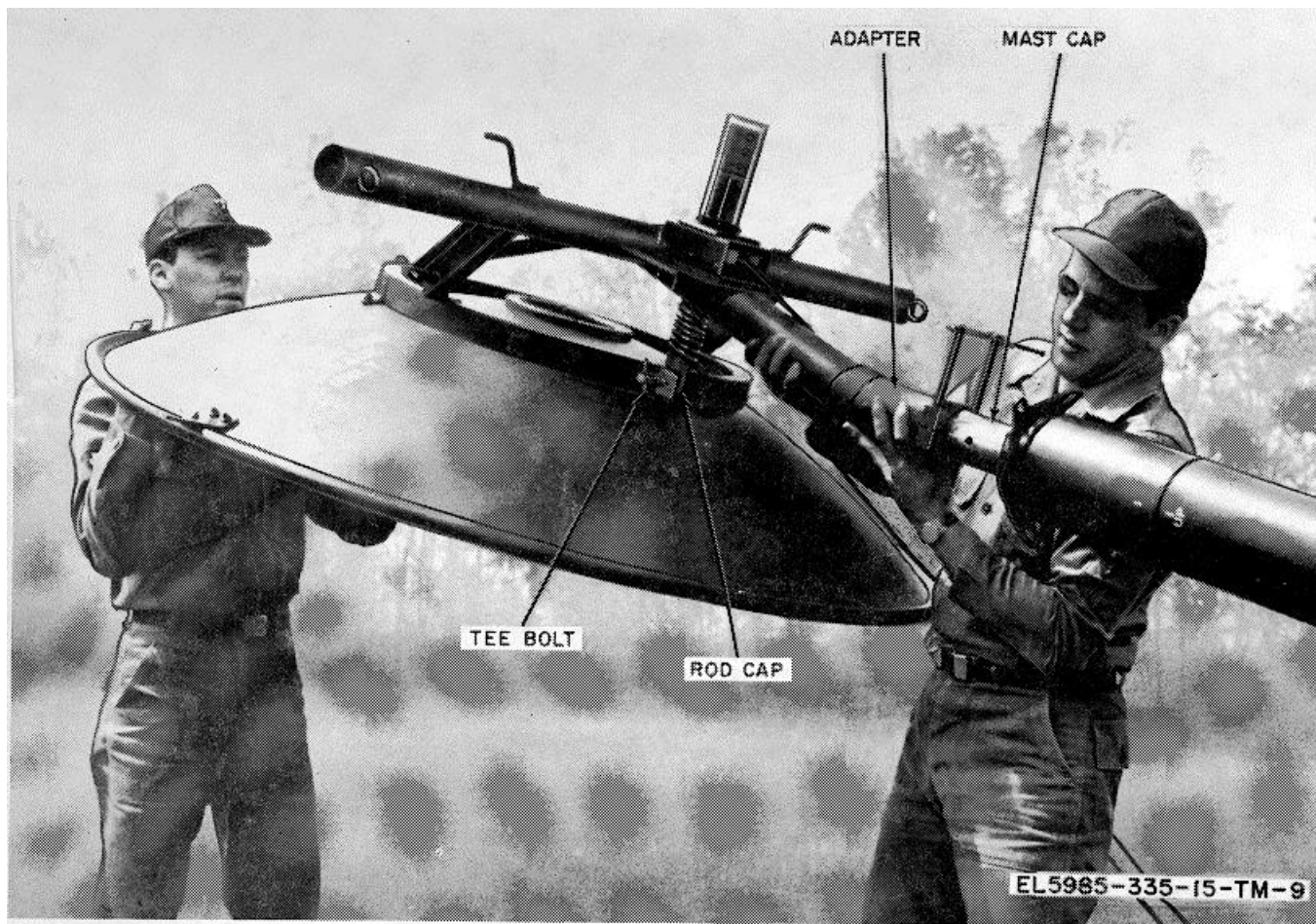
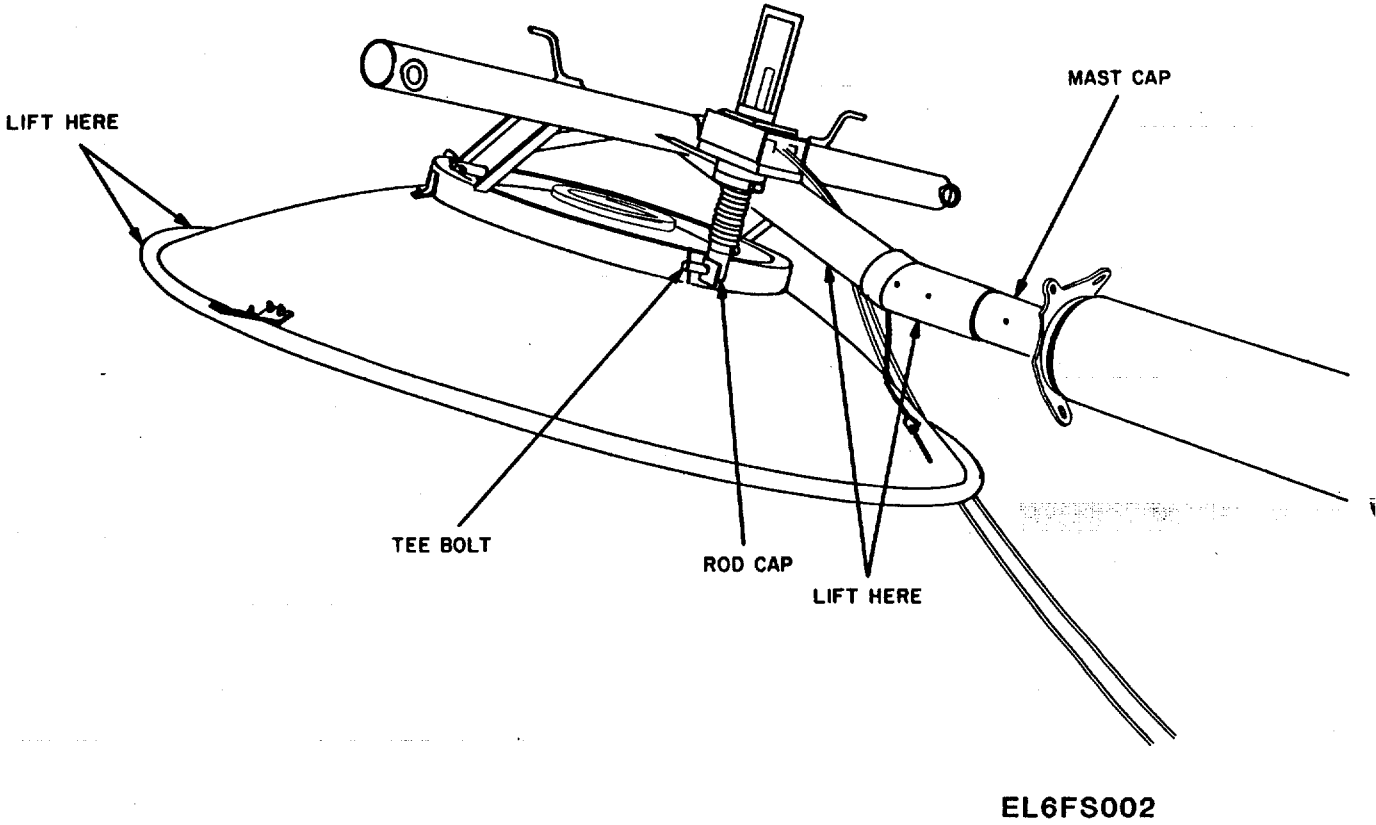

Figure 2-4. Mounting reflector assembly. (A)



■ Figure 2-4.1. Mounting reflector assembly. (B)



■ Figure 2-5. Tightening crosshandle bolts. (A)

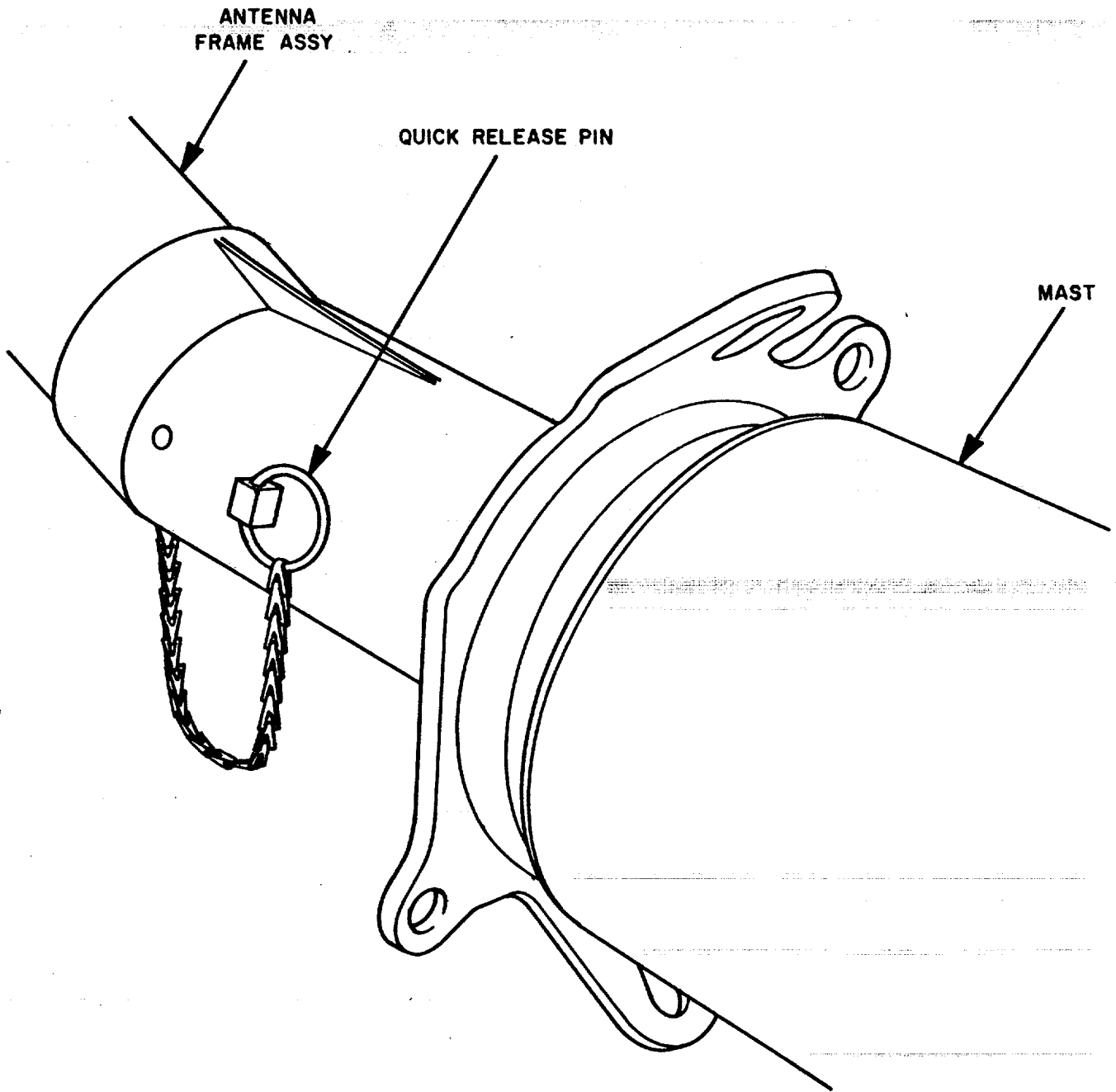

EL6FS003

■ Figure 2-5.1. Antenna mounting secured. (B)

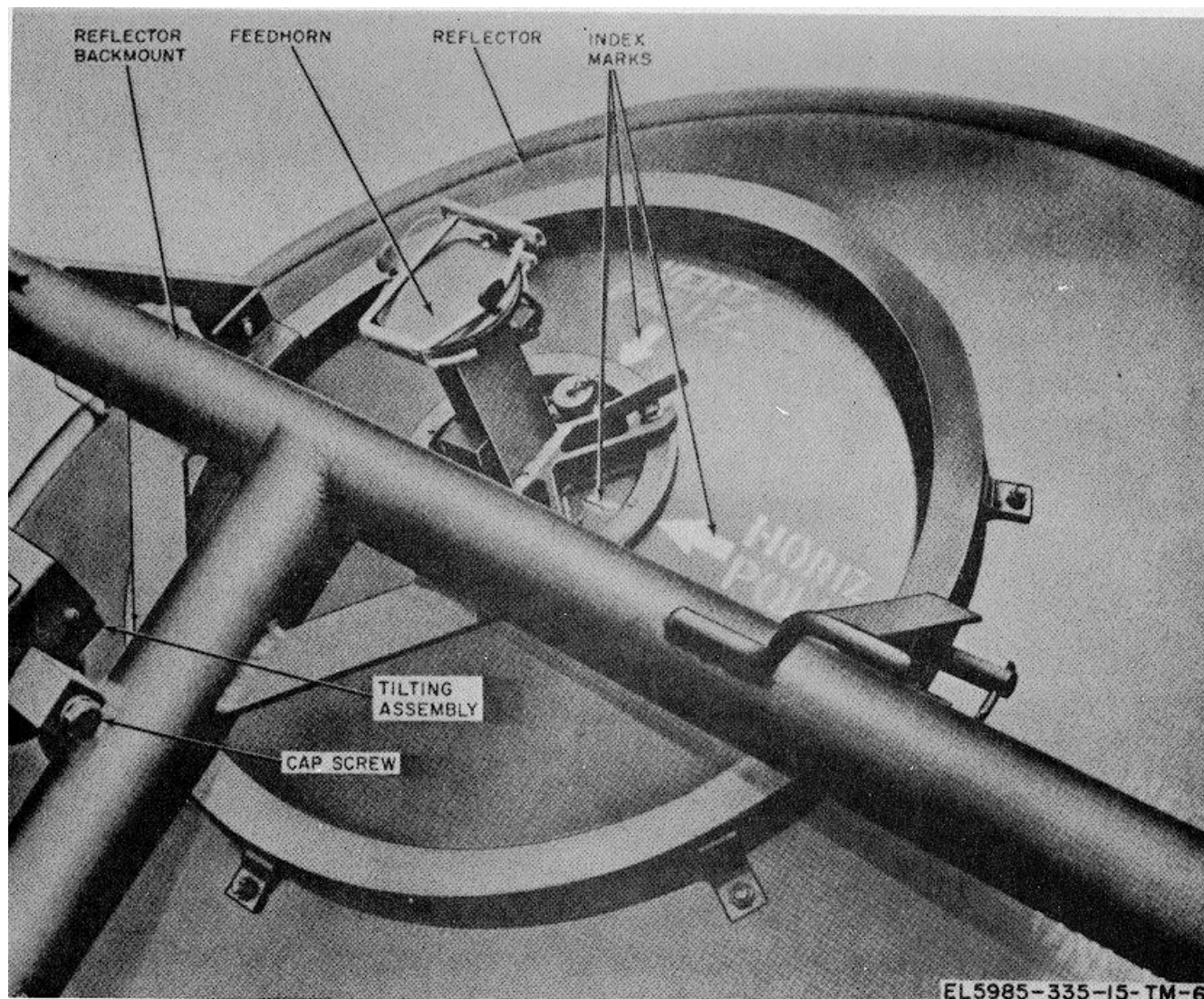

Figure 2-6. Setting antenna polarization.

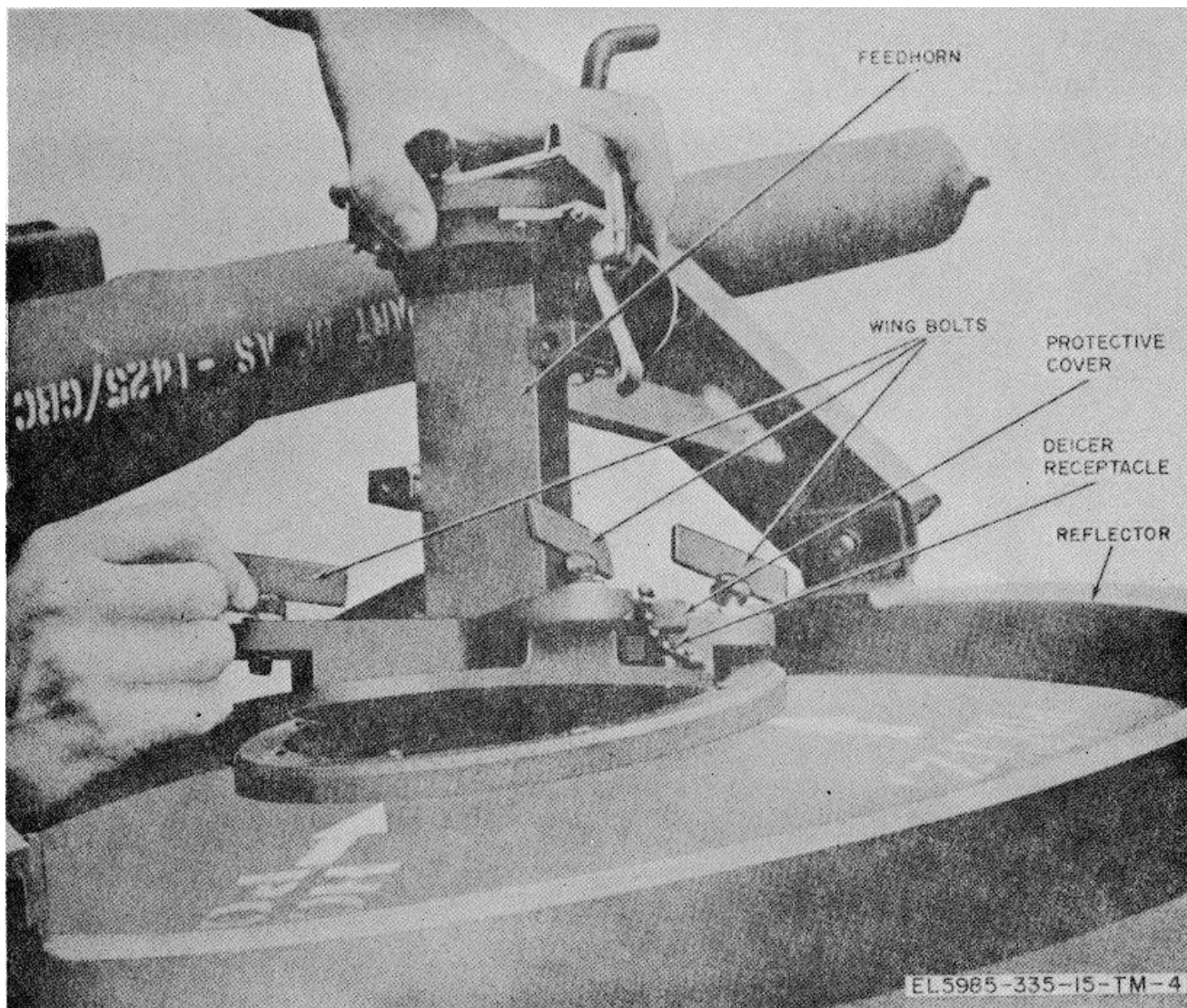

Figure 2-7. Mounting feedhorn to reflector.

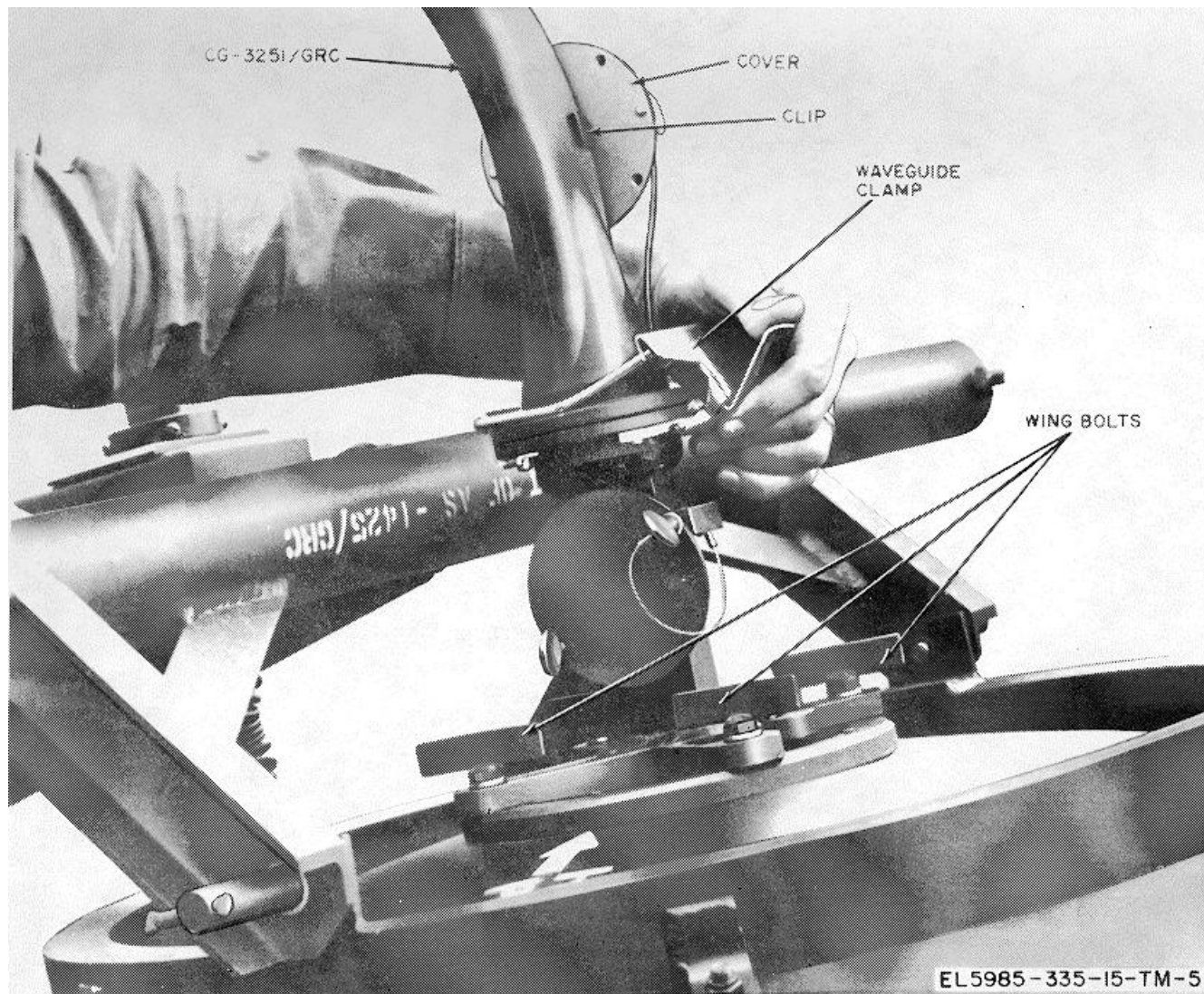

Figure 2-8. Attaching waveguide to feedhorn.

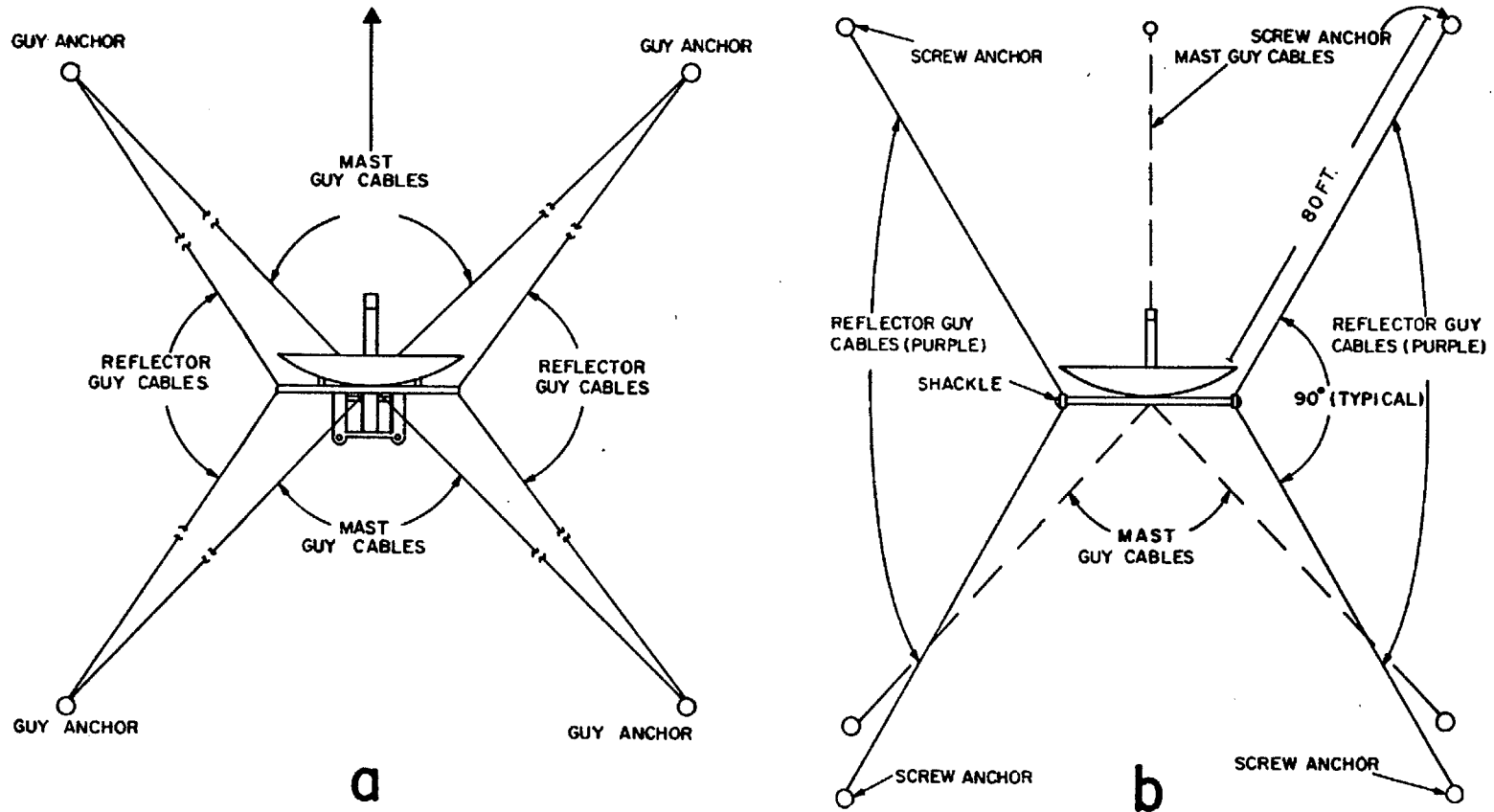

Figure 2-9. Reflectors and guy cable arrangements for (a) Antenna, AS-1425/GRC, and (b) Antenna, AS-1425/GRC with Antenna Extension Kit, MK-2228A/G (used) with Mast AB-621A/G and Mast Extension Kit, MK-2044/G).

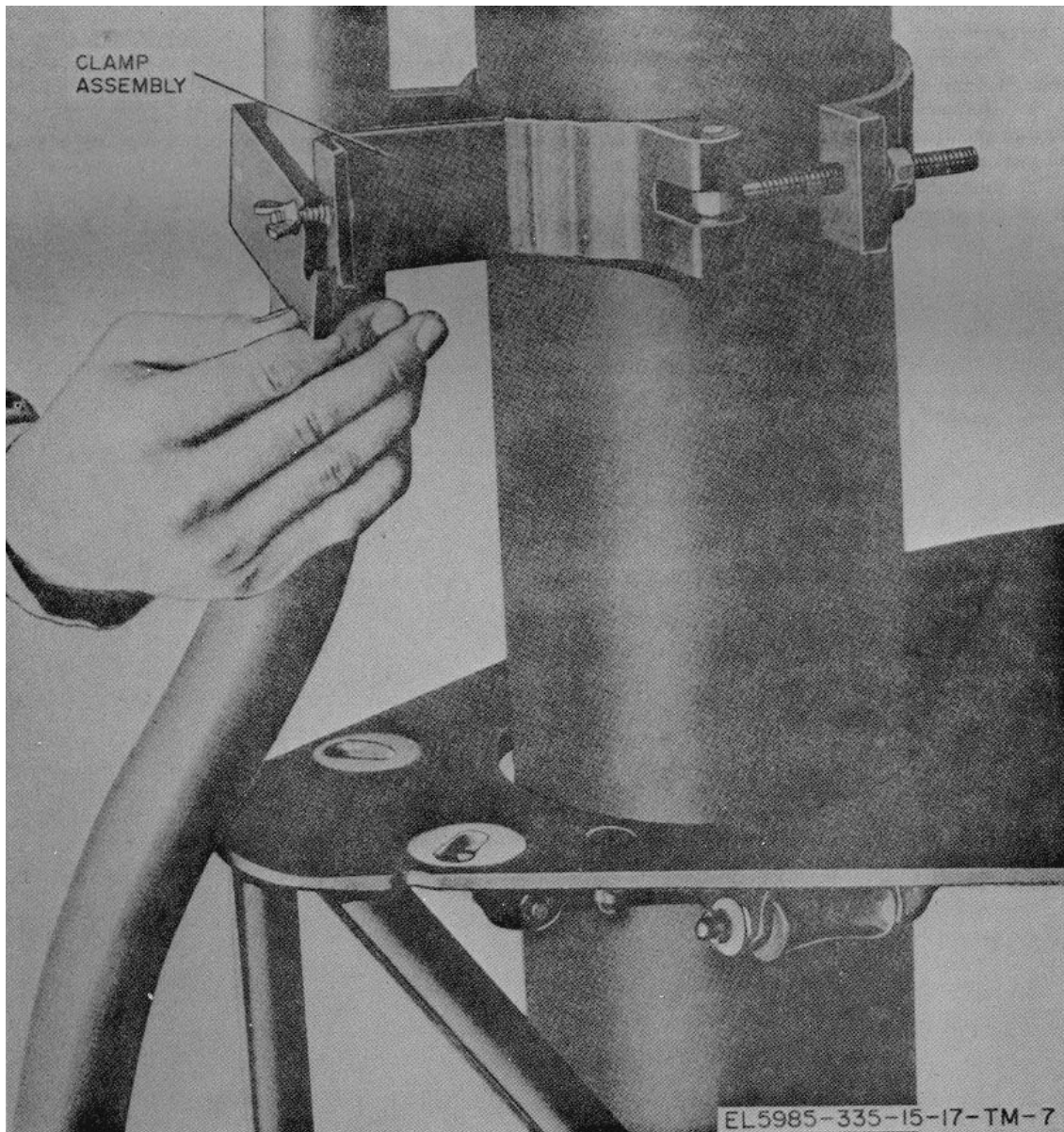

Figure 2-10. Attaching waveguide clamp.

2-7. Antenna Adjustment Procedures

To align the AS-1425/GRC's of two associated radio sets, perform the procedure given in *a* through *h* below:

NOTE

These instructions assume two-terminal link. Repeat these instructions for each additional radio link. Throughout these instructions, one terminal will be referred to as station A and the other terminal will be referred to as station B.

- a. Place in operation the transmitter and receiver at stations A and B.

- b.* Set both receiver meter switches to indicate the rf level of the received signal.
- c.* Establish voice contact between stations A and B. Use the order wire facilities, if incorporated in the associated radio sets. Have station B retransmit to station A the signal received from station A.
- d.* Station a man at each antenna site and provide telephone communications between each antenna site and its associated radio set.
- e.* Instruct the antenna man at station A to rotate his antenna slowly (± 15 degrees off the original position) to obtain at station A a maximum received rf input level indication. If more than one peak is observed, use the peak of maximum amplitude.
- f.* Instruct the antenna man at station A to adjust the antenna tilt angle (using the tilt rope of the tilting assembly) for a maximum received rf input level indication.

g. Instruct the antenna person at station B to rotate the antenna slowly (+15 degrees off the original position) to obtain at station B a maximum received rf input level indication. If more than one peak is observed, use the peak of maximum amplitude.

h. Instruct the antenna person at station B to adjust the antenna tilt angle (using the tilt rope of the tilting assembly) for a maximum received rf input level indication.

2-8. Operation Under Unusual Climatic Conditions

Antenna AS-1425/GRC has been designed to operate under conditions of extreme cold and hot climates. However, additional precautionary measures are necessary to preclude inadvertent damage or degraded operation. The precautionary measures are detailed in a, b, and c below:

a. Subzero temperatures and climatic conditions associated with cold weather affect the operating efficiency of equipment. Extreme cold causes cables and wires to become hard, brittle, and difficult to handle. Ice formations and snow deposits may impede normal operation of moving parts. The following precautionary measures apply:

- (1) Be careful when handling the waveguide sections and power cable so that kinks or unnecessary loops will not form and result in permanent damage.
- (2) Keep protective covers on the feedhorn when the equipment is not in use.
- (3) Do not attempt to rotate the antenna when ice loading on it exceeds the prescribed limits.
- (4) Do not lay tools or parts directly on the ground; use a container or a tarpaulin.
- (5) Operate the antenna deicer equipment.

b. In warm, damp climates or swampy regions, the equipment is subject to damage from moisture and fungus. Observe the following precautions:

(1) Frequently check the antenna for condensed moisture and fungus growths. Thoroughly wipe moisture from the antenna with a lint-free cloth; clean off fungus immediately.

(2) Frequently check the level of the antenna to assure that uneven settling of anchor cables has not occurred. Be sure that anchor cables have not loosened excessively in rain-softened ground.

c. In hot, dry climates, the exposed parts of the antenna are subject to damage from blown dirt and dust. Minimize the effects of dirt, dust, and sand by observing the following precautions:

- (1) Be sure that equipment dust covers are serviceable and are installed when the equipment is not in use.
- (2) Maintain the equipment by cleaning it frequently and immediately after dust storms.

CHAPTER 3

OPERATOR/CREW-AND ORGANIZATIONAL MAINTENANCE INSTRUCTIONS

Section I. OPERATOR/CREW MAINTENANCE

3-1. Scope of Operator/Crew Maintenance

The maintenance duties assigned to the operator of Antenna AS-1425/GRC are listed below together with references to the paragraphs covering the specific maintenance functions. The duties assigned do not require tools or test equipment other than those issued with the equipment.

- a. Preventive maintenance checks and services chart (para 3-5).
- b. Cleaning (para 3-6).
- c. Troubleshooting (para 3-7).

3-2. Tools, Materials, and Test Equipment Required

The only tools and test equipment required for operator maintenance are those furnished with the AS-1425/GRC. The required materials are as follows:

- a. Trichlorotrifluoroethane (NSN 6850-00-105-3084).
- b. Cloth, textile: cheesecloth, lint-free (NSN 8305-00-267-3015),
- c. Abrasive sheet (NSN 5350-00-271-7939),

3-3. Operator/Crew Preventive Maintenance

a. Operator/crew preventive maintenance is the systematic care, servicing and inspection of equipment to prevent the occurrence of trouble, to reduce downtime, and to maintain equipment in serviceable condition. To be sure that your operations central is always ready for your mission, you must do scheduled preventive maintenance checks and services (para 3-5).

- (1) BEFORE OPERATION, perform your B PMCS to be sure that your equipment is ready to go.
- (2) When an item of equipment is reinstalled after removal, for any reason, perform the necessary B PMCS to be sure the item meets the readiness reporting criteria
- (3) Use the ITEM NO. column in the PMCS table to get the number to be used in the TM ITEM NO. column on DA Form 2404 (Equipment Inspection and Maintenance Worksheet) when you fill out the form.

b. Routine checks like CLEANING (para 3-6), DUSTING, WASHING, CHECKING FOR FRAYED CABLES, STOWING ITEMS NOT IN USE, COVERING UNUSED RECEPTACLES, CHECKING FOR LOOSE NUTS AND BOLTS AND CHECKING FOR COMPLETENESS are not listed as PMCS checks. They are things that you should do any time you see they must be done. If you find a routine check like one of those listed in your PMCS, it is because other operators reported problems with this item.

Note: When you are doing any PMCS or routine checks, keep in mind the warnings and cautions.

Warnings: Adequate ventilation should be provided while using TRICHLOROTRIFLUOROETHANE. Prolonged breathing of vapor should be avoided. The solvent should not be used near heat or open flame; the products of decomposition are toxic and irritating. Since TRICHLOROTRIFLUOROETHANE dissolves natural oils, prolonged contact with skin should be avoided. When necessary, use gloves which the solvent cannot penetrate. If the solvent is taken internally, consult a physician immediately.

Compressed air is dangerous and can cause serious bodily harm if protective means or methods are not observed to prevent a chip or particle (of whatever size) from being blown into the eyes or unbroken skin of the operator or other personnel. Goggles must be worn at all times while cleaning with compressed air. Compressed air shall not be used for cleaning purposes except where reduced to less than 29 pounds per square inch gage (psig) and then only with effective chip guarding and personnel protective equipment. Do not use compressed air to dry parts when trichlorotrifluoroethane has been used.

Notes: The PROCEDURES column in your PMCS charts instruct how to perform the required checks and services. Carefully follow these instructions and, if tools are needed or the chart so instructs, get organizational maintenance to do the necessary work.

If your equipment must be in operation all the time, check those items that can be checked and serviced without disturbing operation. Make the complete checks and services when the equipment can be shut down.

c. Deficiencies that cannot be corrected must be reported to higher category maintenance personnel. Records and reports of preventive maintenance must be made in accordance with procedures given in DA Pam 738-750.

3-4. Operator/Crew Preventive Maintenance Checks and Services

Perform before operation PMCS if you are operating the item for the first time.

Note: The checks in the interval column are to be performed in the order listed.

3-5. Operator/Crew Preventive Maintenance Checks and Services Chart

B - Before

Item No.	Interval	Item to be Inspected	Procedures - Check for and have repaired or adjusted as necessary	Equipment is not Ready/Available If:
	B			
1	*	Antenna AS-1425/GRC	Check operation of antenna and Radio Set AN/GRC-147 as described in TM 11-5820-568-12	Equipment cannot receive or transmit.

*Do this check before each deployment to a mission location. This will permit any existing problems to be corrected before the mission starts. The check does not need to be done again until redeployment.

3-6. Cleaning

Warning: Adequate ventilation should be provided while using TRICHLOROTRIFLUOROETHANE. Prolonged breathing of vapor should be avoided. The solvent should not be used near heat or open flame; the products of decomposition are toxic and irritating. Since TRICHLOROTRIFLUOROETHANE dissolves natural oils, prolonged contact with skin should be avoided. When necessary, use gloves which the solvent cannot penetrate. If the solvent is taken internally, consult a physician immediately.

- a. Use a dry, clean, lint-free cloth or brush to remove dust or dirt.
- b. If necessary, moisten the cloth or brush with trichlorotrifluoroethane.

After cleaning, wipe dry with a clean cloth.

3-7. Operator's Troubleshooting

Whenever an equipment trouble occurs, make a visual inspection of all equipment connections before making any detailed troubleshooting procedures. The following visual checks should be made by the operator to determine the possible cause of malfunction.

- a. Check to see that all power cable arrangements are correctly located and secure.
- b. Check to see that the antenna is properly oriented and that the same type of polarization is being used at both communications sites.
- c. Perform other visual checks as indicated in the appropriate technical manuals (appx A) associated with the equipment.

Note: If the trouble is not apparent, or the above checks do not reveal the cause of trouble, higher category maintenance is required.

Section II. ORGANIZATIONAL MAINTENANCE

3-8. Organizational Preventive Maintenance Checks and Services

There are no scheduled organizational preventive maintenance checks and services on this equipment. The operator will perform general maintenance and scheduled PMCS. When a problem develops that is beyond the capabilities of the operator, the operator will advise organizational maintenance on DA Form 2404 and request assistance.

Paragraph 3-9 deleted.

Paragraph 3- 10 deleted.

3-11. Organizational Troubleshooting Information

The troubleshooting and repair work that can be performed at the organizational category of maintenance is necessarily limited in scope by the tools, test equipment, and replaceable parts issue, and by the existing tactical situation. Accordingly, troubleshooting is based on the performance of the equipment and the use of the senses in determining component malfunctions.

3-12. Touchup Painting

Remove rust and corrosion from metal surfaces by lightly sanding them with fine sandpaper. Brush two thin coats of paint on the base metal to protect it from further corrosion. Refer to the applicable cleaning and refinishing practices specified in TB 43-0118.

CHAPTER 4

DIRECT AND GENERAL SUPPORT MAINTENANCE

4-1. Analysis of Operation

a. Signals from an associated transmitter are applied to the AS-1425/GRC feedhorn through a series of waveguides. The mouth of the feedhorn is positioned so as to be at the focal center of the 4-1/2-foot parabolic reflector. Polarization of the transmitted signal is determined prior to installation and is set by manual positioning of the feedhorn mouth (para 2-6). The reflector radiates energy in a direction perpendicular to the plane of the parabolic reflector and provides a gain of at least 33 db in the direction of radiation.

b. Signals received by the parabolic reflector are focused on the mouth of the feedhorn and applied to the waveguide sections for conduction to an associated receiver. The angle of reception and gain is identical to that for transmitting.

4-2. General Maintenance Instructions

a. The preventive maintenance procedures performed at direct and general support categories of maintenance are actions which have been designed to anticipate potential problem areas for the purpose of correcting a possible trouble before it results in equipment outage. The action to be taken consists mainly of the-following:

(1) Visual inspection of the equipment for the purpose of determining general condition, unusual noise, and wear. Generally, the equipment will remain operational when these inspections are made.

(2) Repair or replacement of parts that have a definite life expectancy.

b. The direct and general support maintenance procedures are not complete in themselves but supplement the procedures performed at the organizational category of maintenance and include any additional techniques required to perform maintenance on the AS-1425/GRC.

4-3. Replacement of Components

The components of Antenna AS-1425/GRC can be readily identified upon visual inspection. Detailed parts removal information is given in paragraphs 4-4 through 4-7.

4-4. Removal and Replacement of Tilting Assembly

a. Removal.

(1) Remove the tee bolt (fig. 2-4) securing the tilting assembly to the reflector.

(2) Remove the cap screw (fig. 2-6), lockwashers and washer securing the tilting assembly to the backmount, and remove the tilting assembly.

b. Replacement

(1) Attach the tilting assembly to the backmount using the cap screw, lockwasher, and washer removed in step a. (2) above.

(2) Align the screw insert in the rod cap of the tilting assembly with the reflector flange bracket hole, and secure with the tee bolt (fig. 2-4).

(3) Pull on the tilting rope to insure that the tilting assembly operates.

4-5. Removal and Replacement of Feedhorn.

(fig. 2-7)

a. Removal

(1) Unscrew the power connector plug (not shown) from the deicer receptacle.

(2) Screw the connector cover on the deicer receptacle.

(3) Release the quick-disconnect clamp and move Waveguide Assembly CG-3251/GRC aside.

(4) Unscrew four wing bolts.

(5) Carefully remove the feedhorn from the reflector.

b. Replacement

(1) Check the arrows on the reflector for the polarization desired (fig. 2-6).

(2) Orientate the feedhorn and place it in the reflector opening from the rear.

(3) Screw in the four wing bolts (fig. 2-7).

(4) Place Waveguide Assembly CG-3251/GRC against the feedhorn and close the quick-disconnect clamp.

Note: Perform (5) and (6) below if use of deicer is anticipated.

(5) Remove the connector cover from the deicer receptacle.

(6) Screw the power connector plug (not shown) on the deicer receptacle.

4-6. Removal and Replacement of Feedhorn Iris.

a. Removal

(1) Remove the 10 screws and self-locking nuts securing the outer frame of the feedhorn iris, and remove the outer frame.

(2) Remove the gasket and iris.

b. Replacement

(1) Place the iris and gasket against the feedhorn.

(2) Place the outer frame against the gasket and iris, and replace the 10 securing screws and self-locking nuts removed in a. (1) above. (One of the self-locking nuts is used to secure the ground wire of the heater assembly, as shown in figure 4-1).

4-7. Removal and Replacement of Deicer Equipment

(fig. 4-1)

a. Removal

- (1) Remove the tapes securing the heater and ground wire to the feedhorn, and loosen the self-locking nut that secures the ground wire.
- (2) Disconnect the deicer plug.
- (3) Gently pry the tube out from under the four clips securing it to the feedhorn, and remove the deicer equipment.

b. Replacement

- (1) Connect the deicer plug.
- (2) Gently press the tube into position under the four clips along the length of the feedhorn.
- (3) Wrap the heater around the neck of the feedhorn, and secure the ground wire under the self-locking nut on the feedhorn, as shown in figure 4-1.
- (4) Secure the heater and ground wire to the feedhorn with red electrical tape and overwrap with black electrical tape.
- (5) Seal the ends of the tube and of the tape overwrap with General Electric RTV-103 silicone rubber.

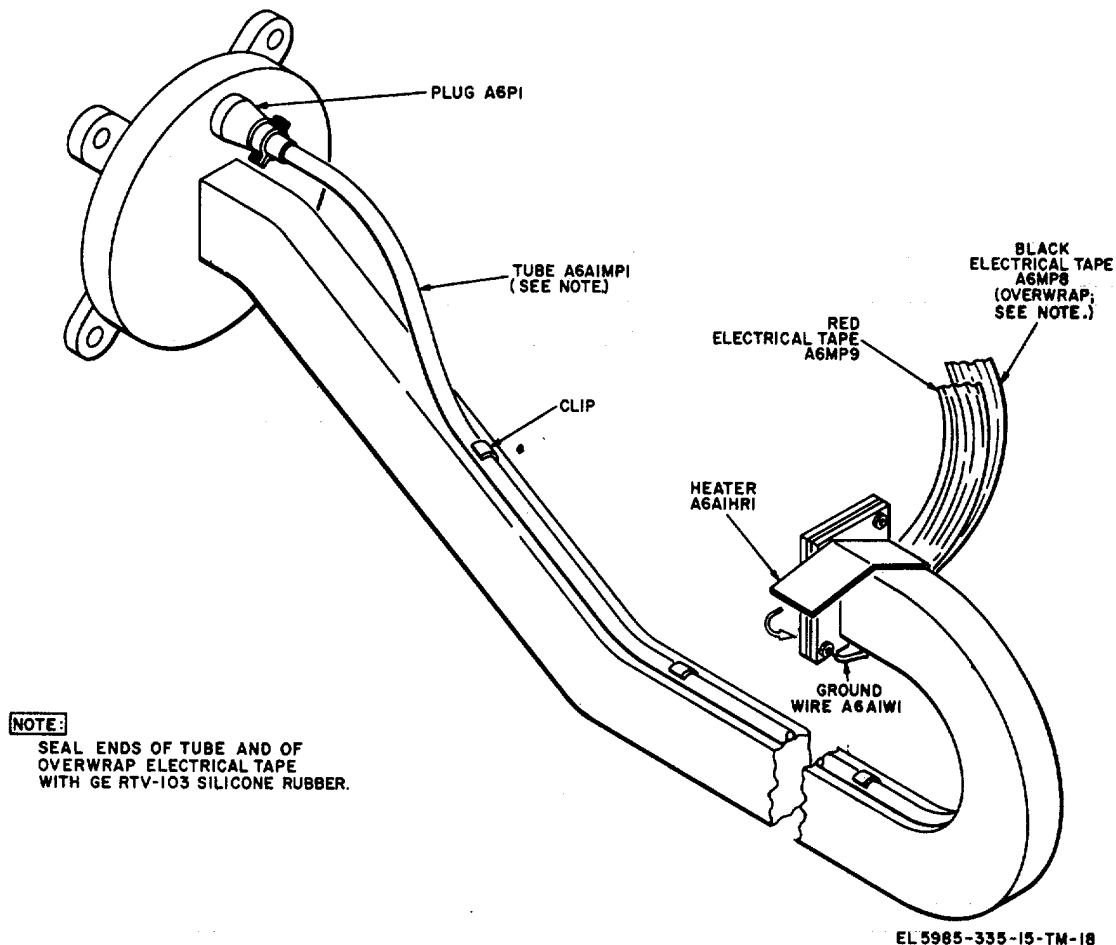

Figure 4-1. Removal and replacement of deicer equipment.

CHAPTER 5

DEPOT MAINTENANCE

Section I. GENERAL INFORMATION

5-1. General.

Complete rebuild of Antenna AS-1425/G)C and/or its individual components may be accomplished by depot maintenance facilities when authorized. Because there are alternate methods to virtually every type of operation, it is not presumed that the tests described in this chapter will be satisfactory for complete acceptance of the equipment. Rather, it is the purpose to merely offer assistance and guidance in the most expedient method of determining that the AS-1425/GRC meets the minimum acceptable limits of system performance.

5-2. Maintenance Procedures.

Detailed procedures for accomplishing the repair and adjustments established in the preceding portions of this manual (and such additional repair and rebuild operations as deemed necessary) will be established by the maintenance facility performing the work. Restore the appearance, performance, and life expectancy of the AS-1425/GRC to a standard comparable to that of new equipment by performing the following procedures:

- a. Disassemble the AS-1425/GRC as required.
- b. Inspect all component parts.
- c. Repair or replace any unserviceable part with one that conforms to the original manufacturing specifications and tolerances.
- d. Reassemble the various component parts.
- e. Perform the depot overhaul standards.

5-3. Removal and Replacement of Reflector.

- a. Removal
 - (1) Remove the tilting assembly (para 4-4a.).
 - (2) Remove the feedhorn (para 4-5a.).
 - (3) Remove the two tee bolts that secure the reflector to the backmount (fig. 2-3) and remove the reflector.
- b. Replacement
 - (1) Position the reflector on the backmount, and engage and secure the two tee bolts removed in step a. (3) above.

- (2) Replace the feedhorn and tilting assembly.

5-4. Disassembly and Reassembly of Tilting Assembly

(fig. 5-1)

a. Disassembly

- (1) Remove the four machine screws (1) and split washers (2), then remove the sleeve spacer (3) and the plastic tube (4) with its attached parts.

Note: The cover (5) cannot be separated from the plastic tube (4).

- (2) If it is necessary to separate the scale plate (6) from the plastic tube (4), remove the two machine screws (7), flat washers (8), and hexagonal self locking nuts (9).

- (3) Remove the seven machine screws (10) and split washers (11), then remove the pulley cover (12) with its attached parts.

(4) If necessary, remove the four machine screws (13) and split washers (14) to separate the sleeve bushing (15) and the mounting plate (16) from the pulley cover (12).

(5) Remove the spring pin (17) from the threaded steel rod (18).

(6) Loosen the screw in the hose clamp (19) and remove the hose clamp.

(7) While holding the groove pulley (38) fixed, unscrew the rod cap (20) with its attached parts.

- (8) If necessary, separate the threaded steel rod (18) from the rod cap (20) by removing the spring pin (21) and/or remove the screw insert (22) from the rod cap (20).

(9) Loosen the screw in the hose clamp (23) and remove the hose clamp.

(10) Remove the rubber boot (24).

- (11) Remove the four machine screws (25), split washers (26), and flat washers (27), and remove the can (28).

(12) Unscrew one of the two hexagonal head cap screws (29) to remove one set of outer sleeve bushing (30), inner sleeve bushing (31), and two flat washers (32). Repeat for the other hexagonal head cap screw (29).

(13) Remove the spliced rope (33).

(14) Remove the four hexagonal head cap screws (34) and split washers (35), then separate the plain round nut (36) and the nonmetallic washer (37) from the groove pulley (38).

(15) If necessary, remove the threaded screw insert (39), four threaded screw inserts (40), and/or two screw inserts (41) from the mounting block (42).

b. Reassembly

- (1) If necessary, cement the cover (5) to the plastic tube (4) using No. CDC502 Cement, G. E. Company, Pittsfield, Mass., or equal.

(2) If necessary, use two machine screws (7), flat washers (8), and hexagonal self locking nuts (9) to attach the scale plate (6) inside the plastic tube (4).

(3) If necessary, insert the threaded screw insert (39), four threaded screw inserts (40), and/or two screw inserts (41) into mounting block (42).

(4) If necessary, insert the screw insert (22) into the rod cap (20), and/or assemble the threaded steel rod (18) to the rod cap with spring pin (17).

(5) If necessary, use the four machine screws (13) and split washers (14) to attach the sleeve bushing (15) and the mounting plate (16) to the pulley cover (12).

(6) Use the four hexagonal head cap screws (34) and split washers (35) to attach the plain round nut (36) and the nonmetallic washer (37) to the groove pulley (38).

(7) Place the spliced rope (33) over the groove pulley (38).

(8) Use one hexagonal head cap screw (29) to attach one set of outer sleeve bushing (30), inner sleeve bushing (31), and two flat washers (32) to the mounting block (42). Repeat with second hexagonal head cap screw (29) for other set.

(9) Use four machine screws (25), split washers (26), and flat washers (27) to attach the can (28) to the mounting block (42).

(10) Position the rubber boot (24) over the can (28), and secure with the hose clamp (23).

(11) While holding the groove pulley (38) fixed, screw the rod cap (20) with its attached parts into the plain round nut (36).

(12) Insert the spring pin (17) into the threaded steel rod (18).

(13) Position the rubber boot (24) over the rod cap (20), and secure with the hose clamp (19).

(14) Use the seven machine screws (10) and split washers (11) to attach the pulley cover (12) with its attached parts to the mounting block (42).

(15) Position the plastic tube (4) and the sleeve spacer (3) over the sleeve bushing (15) in proper alignment, then attach with four machine screws (1) and split washers (2).

Section II. DEPOT OVERHAUL STANDARDS

5-5. Applicability of Depot Overhaul Standards.

The tests outlined in this section are designed to measure the performance capability of repaired equipment. Equipment that is returned to stock should also meet the standards given in the tests.

Key for Figure 5-1

- Notes: 1. Prefix all reference designations by A8.
 2. The two subassemblies of this assembly are:
 A1 - Block Assembly
 A2 - Rod Assembly

- | | |
|--|---|
| 1. Machine Screw MP3H4 | 22. Screw Insert A3MPIH1 |
| 2. Split Washer MP3H8 | 23. Hose Clamp MP10 |
| 3. Sleeve Spacer MP3H1 | 24. Dust and Moisture Proof (Rubber) Boot MP2 |
| 4. Plastic Tube MP16 | 25. Machine Screw MPIIH4 |
| 5. Cover AIMP13 | 26. Split Washer AIMPIIH4 |
| 6. Scale Plate AIMP14 | 27. Flat Washer AIMPIIH4 |
| 7. Machine Screw MP14H2 | 28. Can MP11 |
| 8. Flat Washer MP14H2 | 29. Hexagonal Head Cap Screw MP15H2 |
| 9. Hexagonal Self Locking Nut AIMP14H2 | 30. Outer Sleeve Bushing MP5 and MP6 |
| 10. Machine Screw AIMP12H7 | 31. Inner Sleeve Bushing MP7 and MP8 |
| 11. Split Washer AIMP12H7 | 32. Flat Washer MP15H2 |
| 12. Pulley Cover AIMP12 | 33. Spliced Rope |
| 13. Machine Screw MP3H4 | 34. Hexagonal Head Cap Screw MP15H4 |
| 14. Split Washer MP3H8 | 35. Split Washer MP15H2 |
| 15. Sleeve Bushing MP3 | 36. Plain Round Nut A3H1 |
| 16. Mounting Plate MP4 | 37. Nonmetallic Washer A2H1 |
| 17. Spring Pin A2H1 | 38. Groove Pulley MP15 |
| 18. Threaded Steel Rod A2MP2 | 39. Threaded Screw Insert AIH1 |
| 19. Hose Clamp MP9 | 40. Threaded Screw Insert A1H4 |
| 20. Rod Cap A2MP1 | 41. Screw Insert A1H2 |
| 21. Spring Pin A2MP2H1 | 42. Mounting Block AIMP1 |

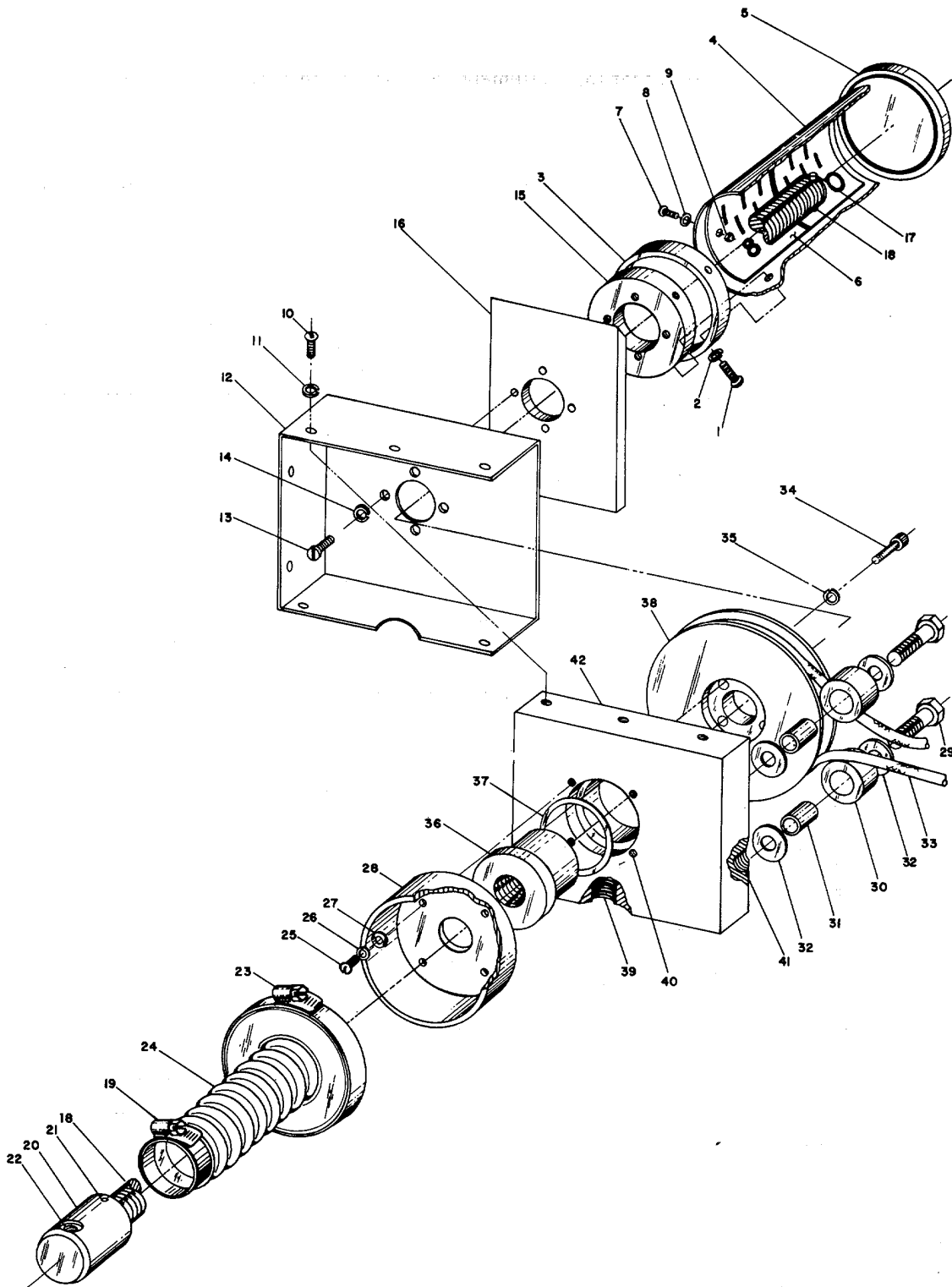

EL 5985-335-15-TM-16

Figure 5-1. Tilting assembly, exploded view.

Note: The following test procedures should not be used to test the performance of new equipment; that is, equipment that has not been repaired or rebuilt. Such equipment should be tested for conformance with the electrical and operational specifications given in the contract under which the equipment was manufactured, including any waivers and/or changes to the equipment that were imposed on or granted to the particular manufacturer of the equipment.

a. Technical publications applicable to the AS-1425/GRC are listed in Appendix A. Applicable procedures and general standards of the Signal Corps depots performing these tests form a part of the requirement for testing this equipment.

b. Perform all applicable modification work orders (MWO's) pertaining to the equipment before performing the test procedures. DA Pam 310-1 lists all current MWO's.

5-6. Test Equipment Required.

The following test equipment is required for depot testing Antenna AS-1425/GRC.

	<u>Test Equipment</u>	<u>NSN</u>
a.	Adapter UG-1490/U	5985-00-772-6676
b.	Radio Frequency Cable Assembly CG-409C/U (4 ft 3 in.)	5995-00-617-1880
c.	Signal Generator AN/URM-52	6625-00-965-1501
d.	Standing Wave Ratio Indicator AN/USM-37E	6625-00-197-6910
e.	Multimeter AN/URM-105	6625-00-581-2036
f.	Slotted Line IM-()/USM-37E G233 (77327)	

5-7. Physical and Deicer Tests.

a. *Visual Tests.* Visually examine the reflector, feedhorn, backmount, antenna adapter, guys, clamp assemblies, cable hangers, and waveguide assemblies. There should be no signs of dents, scratches, or physical distortion of any parts.

b. *Structural Test.*

(1) A tension of not more than 10 pounds should be required to operate the tilting assembly at any angle throughout its range of from -8° to +8°. No restraining force on the rope should be required at any setting. The rope should not slip on the pulley when pulled in either direction.

(2) Hang a 12-pound weight 24 inches from the junction of the feedhorn and its mounting flange. After 5 minutes, the feedhorn should not be displaced by more than 1/4 inch from its original position.

c. *Dimensional Test.* The plotting dimensions for the theoretical curve of the reflector are shown in figure 5-2. The dimensions should be within $\pm 9/64$ inch of these dimensions. If the reflector conforms to these dimensions, the beam width and gain of the AS-1425/GRC are within tolerance.

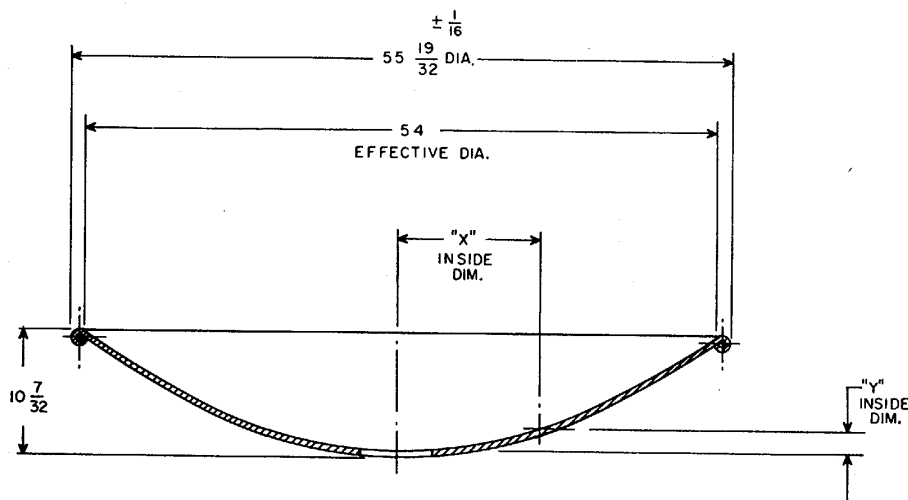

PLOTING DIMENSIONS			
"X"	"Y"	"X"	"Y"
1	.014	15	3.125
2	.056	16	3.556
3	.125	17	4.014
4	.222	18	4.500
5	.347	19	5.014
6	.500	20	5.556
7	.681	21	6.125
8	.889	22	6.722
9	1.125	23	7.347
10	1.389	24	8.000
11	1.681	25	8.681
12	2.000	26	9.389
13	2.347	27	10.125
14	2.722		

EL 5985 - 335-15-TM-17

Figure 5-2. Reflector dimensions.

d. *Deicer Test.* Apply 115 volts, 60 Hz through Multimeter AN/URM-105 () (set to its 500-MA range) to the deicer. The deicer should draw 300 milliamperes, $\pm 10\%$.

5-8. VSWR Test
(fig. &a)

a. *Test Conditions.* The AS-1425/GRC must be mounted to radiate into free space. This requires that obstructions are no closer than 500 feet from the AS-1425/GRC reflector. If required, the AS-1425/GRC may be either elevated to

NOTE

The VSWR is measured at the input to the 60-foot run (minimum length) of Waveguide Assemblies CG7/GRC that feeds the signal from the AN/URM42()

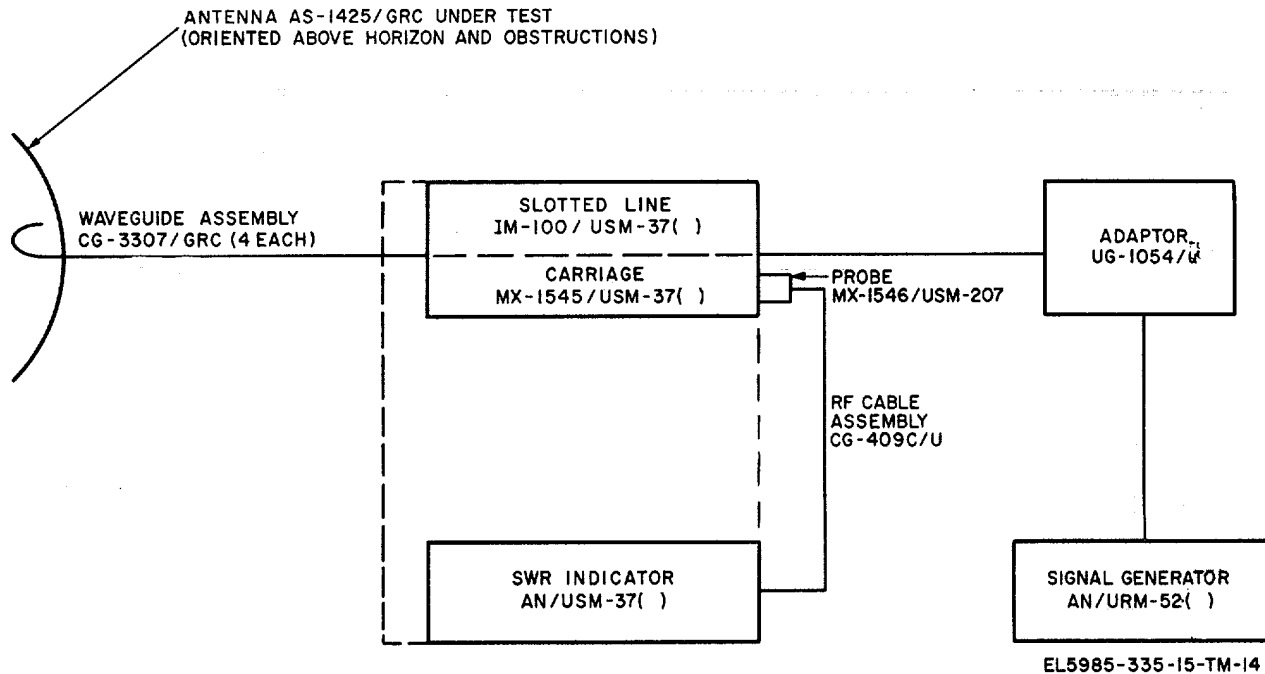

Figure 5-3. VSWR test setup diagram.

b. *Test Procedure.*

- (1) Insure that there are no obstructions within 500 feet of the AS-1425/GRC. If necessary, tilt the antenna above the horizon to clear obstructions.
- (2) Make the test connections shown in figure 54, connecting the output flange of the IM-100/100-37() to the input end of the CG-3307/GRC and the waveguide flange of the UG-1054/u to the input flange of the IM-100/USM47().
- (3) Turn on the AN/URM-52() and the AN/USM-37(), and allow the warm-up periods specified in the test equipment manuals.
- (4) Adjust the AN/URM42() controls for 4.4 GHz at 1 milliwatt (mw) output. Set controls at 1000 Hz square wave modulation.
- (5) The VSWR should not exceed 1.2 to 1 as measured on the AN/USM-37().
- (6) Set the AN/URM-52() output frequency at 4.7 GHz, maintaining the 1-mw output level.
- (7) The VSWR should not exceed 1.2 to 1.
- (8) Set the AN/URM-52() output frequency at 5.0 GHz, maintaining the 1-mw output level.
- (9) The VSWR should not exceed 1.2 to 1.

CHAPTER 6

SHIPMENT AND LIMITED STORAGE

6-1. Disassembly of Equipment

The following instructions are recommended as a guide for preparing Antenna AS-1425/GRC for shipment and limited storage. Disassembly procedures for the antenna are as follows:

- a. Disconnect the flexible waveguide sections starting at the shelter entrance.
- b. Release the tension on the messenger cable and remove the cable with its hangers.
- c. Release the tension on the guy cables.
- d. Lower the mast holding the antenna as described in the technical manual for the mast being used.
- e. Reverse the antenna erection procedure in paragraph 2-6 to disassemble and remove the antenna reflector, backmount and guys.

6-2. Repackaging for Shipment or Limited Storage

The exact procedure for repackaging depends on the material available and the conditions under which the AS-1425/GRC is to be shipped or stored. Adapt the procedures outlined below whenever possible. Refer to paragraph 2-3 for dimensions of the wooden box and cartons originally supplied with the AS-1425/GRC and to figure 2-1 for an illustration of a typical wooden box and its contents.

- a. **Material Requirements.** The following materials are required for packaging the AS-1425/GRC. For stock numbers of materials, consult SB 38-100.

<u>Material</u>	<u>Quantity</u>
Steel strapping	60 feet
Waterproof tape	180 feet
Corrugated cardboard	440 square feet
Waterproof barrier	560 square feet
Adhesive tape	90 feet
Filler material	75 square feet
Dehydrating agent	32 units (16 units per pound)

b. Wrapping. The items of the AS-1425/GRC are to be wrapped as outlined below.

(1) Antenna. Wrap the antenna with filler material to cushion all surfaces. Use adhesive tape to hold the filler material.

(2) Waveguide components. Cushion all waveguide components with filler material and wrap in waterproof barrier. Secure the wrapping with adhesive tape.

(3) Miscellaneous accessories. Wind guys in convenient size rolls and tie with cotton twine.

c. Packaging

(1) Pack the waveguide components and hanger assemblies into corrugated cardboard boxes and secure with waterproof tape.

(2) Pack all other parts in a wooden box (in a sequence similar to that shown in figure 2-1). Be sure that the box is properly packed with filler material to prevent equipment movement while shipping. Nail the box closed, then apply steel strapping.

■ Section II deleted.

APPENDIX A REFERENCES

DA Pam 310-1	Consolidated Index of Army Publications and Blank Forms.
DA Pam 738-750	The Army Maintenance Management System (TAMMS).
SB 11-573	Painting and Preservation of Supplies Available for Field Use for Electronics Command Equipment.
SB 38-100	Preservation, Packaging, Packing and Marking Materials, Supplies, and Equipment Used by the Army.
TB 43-0118	Field Instructions for Painting or Preserving Electronic Command Equipment Including Camouflage Pattern Painting of Electrical Equipment Shelters.
TB SIG 222	Solder and Soldering.
TB SIG 291	Safety Measures to be Observed When Installing and Using Whip Antennas, Field Type Masts, Towers, Antennas, and Metal Poles That are Used With Communication, Radar, and Direction Finding Equipment.
TB SIG 355-1	Depot Inspection Standard for Repaired Signal Equipment.
TB SIG 355-2	Depot Inspection Standard for Refinishing Repaired Signal Equipment.
TB SIG 355-3	Depot Inspection Standard for Moisture and Fungus Resistant Treatment.
TM 11-5820-568-12	Operator's and Organizational Maintenance Manual Including Repair Parts and Special Tools List: Radio Set AN/GRC-147 (NSN 5820-00-935-0004).
TM 11-5820-568-35	DS, GS, and Depot Maintenance Manual: Radio Set AN/GRC-147 (NSN 5820-00-935-0004).
TM 11-5985-335-24P	Organizational, DC, and GS Maintenance Repair Parts and Special Tools List (including Depot Maintenance Repair Parts and Special Tools): Antenna AS-1425/GRC (NSN 5985- 00-926-2593).
TM 11-6625-203-12	Operator and Organizational Maintenance: Multimeter AN/URM-105, and AN/URM-105C Including Multimeter ME-77/U.
TM 11-6625-214-12	Operator's and Organizational Maintenance Manual for Signal Generator AN/URM-52 (NSN 6625-00-556-8017), AN/URM-52A (NSN 6625-00-592-5742) and AN/URM-52B (NSN 6625-00-965-1501).
TM 740-90-1	Administrative Storage of Equipment.
TM 750-244-2	Procedures for Destruction of Electronics Materiel to Prevent Enemy Use.

**APPENDIX B
BASIC ISSUE ITEMS LIST**

Section I. INTRODUCTION

B1-1. Scope.

This appendix lists items which accompany the AS-1425/GRC or are required for installation, operation, or operator's maintenance.

B1-2. General.

This Basic Issue Items List is divided into the following sections:

a. Basic Issue Items - Section II. A list of items which accompany the AS-1425/GRC and are required by the operator/crew for installation, operation, or maintenance.

b. Maintenance and Operating Supplies - Section III. Not applicable.

B1-3. Explanation of Columns.

The following provides an explanation of columns in the tabular-list of Basic Issue Items, Section II.

- a. Source, Maintenance, and Recoverability Codes (SMR), Column 1:
(1) Source code, indicates the selection status and source for the listed item.

Source codes are:

<u>Code</u>	<u>Explanation</u>
<u>P</u>	Repair parts which are stocked in or supplied from the GSA/DSA, or Army supply system and authorized for use at indicated maintenance categories.
<u>P2</u>	Repair parts which are procured and stocked for insurance purposes because the combat or military essentially of the end item dictates that a minimum quantity be available in the supply system.
<u>P9</u>	Assigned to items which are NSA design controlled: unique repair parts, special tools, test, measuring and diagnostic equipment, which are stocked and supplied by the Army COMSEC logistic system, and which are not subject to the provisions of AR 380-41.
<u>P10</u>	Assigned to items which are NSA design controlled: special tools, test, measuring and diagnostic equipment for COMSEC support, which are accountable under the provisions of AR 380-41, and which are stocked and supplied by the Army COMSEC logistic system.

<u>Code</u>	<u>Explanation</u>
<u>M</u>	Repair parts which are not procured or stocked, but are to be manufactured in indicated maintenance levels.
<u>A</u>	Assemblies which are not procured or stocked as such, but are made up of two or more units. Such component units carry individual stock numbers and descriptions, are procured and stocked separately and can be assembled to form the required assembly at indicated maintenance categories.
<u>X</u>	Parts and assemblies which are not procured or stocked and the mortality of which normally is below that of the applicable end item or component. The failure of such part or assembly should result in retirement of the end item from the supply system.
<u>X1</u>	Repair parts which are not procured or stocked. The requirement for such items will be filled by use of the next higher assembly or component.
<u>X2</u>	Repair parts which are not stocked. The indicated maintenance category requiring such repair parts will attempt to obtain same through, cannibalization. Where such repair parts are not obtainable through cannibalization, requirements will be requisitioned, with accompanying justification, through normal supply channels.
<u>G</u>	Major assemblies that are procured with PEMA funds for initial issue only as exchange assemblies at DSU and GSU level. These assemblies will not be stocked above DS and GS level or returned to depot supply level.

(2) Maintenance code, indicates the lowest category of maintenance authorized to install the listed item. The maintenance level code is:

<u>Code</u>	<u>Explanation</u>
<u>C</u>	Operator/Crew

(3) Recoverability code, indicates whether unserviceable items should be returned for recovery or salvage. Items not coded are expendable. Recoverability codes are:

<u>Code</u>	<u>Explanation</u>
R	Repair parts and assemblies that are economically repairable at DSU and GSU activities and are normally furnished by supply on an exchange basis.
S	Repair parts and assemblies which are economically repairable at DSU and GSU activities and which normally are furnished by supply on an exchange basis. When items are determined by a GSU to be uneconomically repairable, they will be evacuated to a depot for evaluation and analysis before final disposition.
T	High dollar value recoverable repair parts which are subject to special handling and are issued on an exchange basis. Such repair parts normally are repaired or overhauled at depot maintenance activities.
U	Repair parts specifically selected for salvage by reclamation units because of precious metal content, critical materials, or high dollar value reusable casings or castings.

b. National Stock Number, Column-2. This column indicates the National stock number assigned to the item and will be used for requisitioning purposes.

c. Description, Column 3. This column indicates the Federal item name and any additional description of the item required. A part number or other reference number is followed by the applicable five-digit Federal 'supply code for manufacture in parentheses.

d. Unit of Measure (U/M), Column 4. A two-character alphabetic abbreviation indicating the amount or quantity of the item upon which the allowances are based, e.g., ft, ea, pr, etc.

e. Quantity Incorporated in Unit, Column 5. This column indicates the quantity of the item used in the AS-1425/GRC.

f. Quantity Furnished with Equipment, Column 6. This column indicates the quantity of an item furnished with the equipment.

g. Illustrations, Column 7. This column is divided as follows:

(1) Figure number, column 7a. This column indicates the figure number of the illustration in which the item is shown.

(2) Item number or reference designation, column 7b. This column indicates the reference designation used to identify the item in the illustration.

B1-4. Explanation of Columns in the Tabular List of Maintenance and Operating Supplies - Section III.

Not Applicable.

Section II. BASIC ISSUE ITEMS

(1) SMR CODE	(2) NATIONAL STOCK NUMBER	(3) DESCRIPTION USABLE ON CODE NUMBER & MFR CODE	(4) UNIT OF MEAS	(5) QTY FURN WITH EQUIP	(6) QTY FURN WITH EQUIP	(7) ILLUSTRATIONS	
						(a) FIGURE NUMBER	(b) ITEM NO. OR REFERENCE DESIGNATION
	5985-00-926-2593	ANTENNA AS-1425/GRC: "Consisting of the following items required to have a complete operable equipment."					
	5985-00-477-8335	ADAPTER, ANTENNA SMC561779-1: 80063 (1 ea)	A			1-1 ①	MP1
	5985-00-13-4418	FRAME, ASSEMBLY SMD561727: 80063 (1 ea)				1-1 ①	A7
	5985-00-168-4274	HORN, ASSEMBLY SME561641: 80063 (1 ea)				1-1 ①	A6
	5975-00-403-1011	GUY SMD561910: 80063 (1 ea)				1-1 ②	A1
	5975-00-403-1012	GUY SMC561651: 80063 (4 ea)				1-1 ①	A2
	5340-00-422-2116	HANGER ASSEMBLY SMC559889: 80063 (15 ea)				1-1 ①	MP11
	5985-00-477-8334	REFLECTOR, ASSEMBLY SMD561729: 80063 (1 ea)				1-1 ①	A9
	5985-00-117-2900	HOUSING, ASSEMBLY SMD561642: 80063 (1 ea)				1-1 ①	A8
	5985-00-9544946	WAVEGUIDE ASSEMBLY CG-3250/GRC (1 ea)				1-1 ②	MP12
	5985-00-9544940	WAVEGUIDE ASSEMBLY CG-3307/GRC (6 ea)					MP13
	5985-00-9544939	WAVEGUIDE ASSEMBLY CG-3251/GRC (2 ea)				1-1 ②	MP14
		TECHNICAL MANUAL TM II-5985-335-15 (1 ea) Requisition through pinpoint account number if assigned; otherwise through nearest Adjutant General facility. For technical manuals, the quantity indicates the maximum number of copies authorized for packing (or issue) with the equipment. Where a number of these equipments are concentrated in a small area, the quantity on hand may be reduced to minimum actual requirements as deter- mined by the commanding officer of the unit.					
		"OPERATOR/CREW REPAIR PARTS, ACCESSORIES, TOOLS AND TEST EQUIPMENT"					
P C	5340-00-407-2814	CLAMP, ASSEMBLY SMD559875: 80063 No Basic Issue Items are Mounted in or on the Equipment.	ea	8	10	1-1 ②	MP12

APPENDIX C
MAINTENANCE ALLOCATION

Section I. INTRODUCTION

C-1. General

This appendix provides a summary of the maintenance operations for Antenna AS-1425/ GRC. It authorizes categories of maintenance for specific maintenance functions on repairable items and components and the tools and equipment required to perform each function. This appendix may be used as an aid in planning maintenance operations.

C-2. Maintenance Function

Maintenance functions will be limited to and defined as follows:

- a. Inspect. To determine the serviceability of an item by comparing its physical, mechanical, and/or electrical characteristics with established standards through examination.
- b. Test. To verify serviceability and to detect incipient failure by measuring the mechanical or electrical characteristics of an item and comparing those characteristics with prescribed standards.
- c. Service. Operations required periodically to keep an item in proper operating condition, i.e., to clean (decontaminate), to preserve, to drain, to paint, or to replenish fuel, lubricants, hydraulic fluids, or compressed air supplies.
- d. Adjust. To maintain, within prescribed limits, by bringing into proper or exact position, or by setting the operating characteristics to the specified parameters.
- e. Align. To adjust specified variable elements of an item to bring about optimum or desired performance.
- f. Calibrate. To determine and cause corrections to be made or to be adjusted on instruments or test measuring and diagnostic equipments used in precision measurement. Consists of comparisons of two instruments, one of which is a certified standard of known accuracy, to detect and adjust any discrepancy in the accuracy of the instrument being compared.
- g. Install. The act of emplacing, seating, or fixing into position an item, part, module (component or assembly) in a manner to allow the proper functioning of the equipment or system.
- h. Replace. The act of substituting a serviceable like type part, subassembly, or module (component or assembly) for an unserviceable counterpart.

i. Repair. The application of maintenance services (inspect, test, service, adjust, align, calibrate, replace) or other maintenance actions (welding, grinding, riveting, straightening, facing, remachining, or resurfacing) to restore serviceability to an item by correcting specific damage, fault, malfunction, or failure in a part, subassembly, module (component or assembly), end item, or system.

j. Overhaul. That maintenance effort (service/action) necessary to restore an item to a completely serviceable/operational condition as prescribed by maintenance standards (i.e., DMWR) in appropriate technical publications. Overhaul is normally the highest degree of maintenance performed by the Army. Overhaul does not normally return an item to like-new condition.

k. Rebuild. Consists of those services/actions necessary for the restoration of unserviceable equipment to a like-new condition in accordance with original manufacturing standards. Rebuild is the highest degree of materiel maintenance-applied to Army equipment. The rebuild operation includes the act of returning to zero those age measurements (hours, miles, etc.) considered in classifying Army equipments/components.

C-3. Column Entries

a. Column 1, Group Number. Column 1 lists group numbers, the purpose of which is to identify components, assemblies, subassemblies, and modules with the next higher assembly.

b. Column 2, Component/Assembly. Column 2 contains the noun names of components, assemblies, subassemblies, and modules for which maintenance is authorized.

c. Column 3, Maintenance Functions. Column 3 lists the functions to be performed on the item listed in column 2. When items are listed without maintenance functions, it is solely for purpose of having the group numbers in the MAC and RPSTL coincide.

d. Column 4, Maintenance Category. Column 4 specifies, by the listing of a "work time" figure in the appropriate subcolumn(s), the lowest level of maintenance authorized to-perform the function listed in column 3. This figure represents the active time required to perform that maintenance function at the indicated category of maintenance. If the number or complexity of the tasks within the listed maintenance function vary at different maintenance categories, appropriate "work time" figures will be shown for each category. The number of task-hours specified by the "work time" figure represents the average time required to restore an item (assembly, subassembly, component, module, end item or system) to a serviceable condition under typical field operating conditions. This time includes preparation

time, troubleshooting time, and quality assurance/quality control time in addition to the time required to perform the specific tasks identified for the maintenance functions authorized in the maintenance allocation chart. Subcolumns of column 4 are as follows:

- C - Operator/Crew
- O - Organizational
- F - Direct Support
- H - General Support
- D - Depot

e. Column 5, Tools and Equipment. Column 5 specifies by code, those common tool sets (not individual tools) and special tools, test, and support equipment required to perform the designated function.

f. Column 6, Remarks. Column 6 contains an alphabetic code which leads to the remark in section IV, Remarks, which is pertinent to the item opposite the particular code.

C-4. Tool and Test Equipment Requirements (Sect. 111)

a. Tool or Test Equipment/Reference Code. The numbers in this column coincide with the numbers used in the tools and equipment column of the MAC. The numbers indicate the applicable tool or test equipment for the maintenance functions.

b. Maintenance Category. The codes in this column indicate the maintenance category allocated the tool or test equipment.

c. Nomenclature. This column lists the noun name and nomenclature of the tools and test equipment required to perform the maintenance functions.

d. National/NATO Stock Number. This column lists the National/NATO stock number of the specific tool or test equipment.

e. Tool Number. This column lists the manufacturer's part number of the tool followed by the Federal Supply Code for manufacturers (5-digit) in parentheses.

C-5. Remarks (Sect. IV)

a. Reference Code. This code refers to the appropriate item in section II, column 6.

b. Remarks. This column provides the required explanatory information necessary to clarify items appearing in section II.

SECTION II MAINTENANCE ALLOCATION CHART
FOR

ANTENNA AS-1425/GRC

(1) GROUP NUMBER	(2) COMPONENT/ASSEMBLY	(3) MAINTENANCE FUNCTION	(4) MAINTENANCE CATEGORY					(5) TOOLS AND EQPT.	(6) REMARKS	
			C	O	F	H	D			
00	Antenna AS-1425/GRC	Inspect	2.0						} A	
		Test	1.0							
		Service	2.0							
		Install		2.0				1, 2		
		Repair		2.0				1, 2	D	
		Repair				2.0			1, 3	
		Overhaul						8.0	3	B
		Test					2.0	1, 4 thru 7		
01	SM-D-561729 Reflector	Inspect	0.5							
		Service	1.0							
		Replace		1.0				2		
		Repair		1.0				2	C	
02	SM-E-561641 Horn Assembly Waveguide Feed	Inspect	1.0							
		Service	0.5							
		Replace		1.0						
		Repair			1.0		3	E		
03	SM-D-561642 Housing , Assembly Elevation Adjust	Inspect	0.5							
		Service	0.2							
		Replace		0.5						
		Repair			2.0			3		

SECTION III TOOL AND TEST EQUIPMENT REQUIREMENTS
FOR

ANTENNA AS-1425/GRC

TOOL/TEST EQUIPMENT REF. CODE	MAINTENANCE CATEGORY	NOMENCLATURE	NATIONAL NATO STOCK NUMBER	TOOL NO.
1	O, F, D	Multimeter AN/URM-105	6625-00-581-2036	
2	O	Tool Kit, Electronic Equipment TK-101/G	5180-00-064-5178	
3	F, D	Tool Kit, Electronic Equipment TK-100/G	5180-00-605-0079	
4	D	Adapter UG-1490/U	5985-00-772-6676	
5	D	Slotted Line IM-(U)/USM-37E G233 (77327)		
6	D	Signal Generator AN/URM-52	6625-00-965-1501	
7	D	Indicator Standing Wave Ratio AN/USM-37E	6625-00-197-6910	

SECTION IV REMARKS
FOR
ANTENNA AS-1425/GRC

CODE	REMARKS
A	Crew level, preventive maintenance IAW TM 11-5985-335-15, includes: visual inspection of functional groups 01 through 03 and parts associated with group 00; operational tests using associated radio set.
B	All precision repairs. Restore equipment as near as possible to original condition using manufacturer's tolerances.
C	Reflector only, field expedient repairs in accordance with TM 11-5985-335-13
D	Repair by replacement of reflector assembly, horn assembly, waveguide feed, frame assembly, housing assembly, elevation adjust, guy wire assembly, messenger cable assembly and clamp assembly.
E	Repair by replacement of iris assembly and of deicer assembly.

APPENDIX D

ORGANIZATIONAL, DIRECT SUPPORT, GENERAL SUPPORT, AND DEPOT MAINTENANCE REPAIR PARTS AND SPECIAL TOOLS LIST

Section I. INTRODUCTION

D1-1. Scope.

This appendix lists repair parts and special tools required for the performance of organizational, direct support, general support, and depot maintenance of the AS-1425/GRC.

D1-2. General.

This Repair Parts and Special Tools List is divided into the following sections:

a. Prescribed Load Allowance (PLA) - Section II. A composite listing of repair parts, special tools, test and support equipment having quantitative allowances for initial stockage at the organizational level.

b. Repair Parts for Organizational Maintenance - Section III. A list of repair parts authorized for the performance of maintenance at the organizational level.

c. Special Tools, Test, and Support Equipment - Section IV. Not applicable.

d. Repair Parts for Direct Support, General Support, and Depot Maintenance -Section V. A list of repair parts authorized for the performance of maintenance at the direct support, general support, and depot level.

e. Special Tools, Test, and Support Equipment for Direct Support, General Support, and Depot Maintenance - Section VI. Not applicable.

f. Index - Federal Stock Number Cross Reference to Figure and Item Number or Reference Designation - Section VII. A list of Federal stock numbers in ascending numerical sequence, followed by a list of reference numbers appearing in ascending alpha-numeric sequence, cross-referenced to the illustration figure number and reference designation.

g. Index - Reference Designation Cross Reference to Page Number - Section VIII.

A list of reference designations cross-referenced to page numbers.

D1-3. Explanation of Columns.

The following provides an explanation of columns in the tabular lists:

a. Source, Maintenance, and Recoverability Codes (SMR).

(1) Source code indicates the selection status and source for the list item Source codes are:

<u>Code</u>	<u>Explanation</u>
<u>P</u>	Repair parts which are stocked in or supplied from the GSA/DSA, or Army Supply system and authorized for use at indicated maintenance categories.
<u>P2</u>	Repair parts which are procured and stocked for insurance purposes because the combat or military essentiality of the end item dictates that a minimum quantity be available in the supply system.
<u>P9</u>	Assigned to items which are NSA design controlled: unique repair parts, special tools, test, measuring and diagnostic equipment, which are stocked and supplied by the Army COMSEC logistic system, and which are not subject to the provisions of AR 380-41.
<u>P10</u>	Assigned to items which are NSA design controlled: special tools, test, measuring and diagnostic equipment for COMSEC support, which are accountable under the provisions of AR 380-41, and which are stocked and supplied by the Army COMSEC logistic system.
<u>M</u>	Repair parts which are not procured or stocked, but are to be manufactured in indicated maintenance levels.
<u>A</u>	Assemblies which are not procured or stocked as such, but are made up of two or more units. Such component units carry individual stock numbers and descriptions, are procured and stocked separately and can be assembled to form the required assembly at indicated maintenance categories.
<u>X</u>	Parts and assemblies which are not procured or stocked and the mortality of which normally is below that of the applicable end item or component. The failure of such part or assembly should result in retirement of the end item from the supply system.
<u>X1</u>	Repair parts which are not procured or stocked. The requirement for such items will be filled by use of the next higher assembly or component.
<u>X2</u>	Repair parts which are not stocked. The indicated maintenance category requiring such repair parts will attempt to obtain same through cannibalization. Where such repair parts are not obtainable through cannibalization, requirements will be requisitioned, with accompanying justification, through normal supply channels.
<u>G</u>	Major assemblies that are procured with PEMA funds for initial issue only as exchange assemblies at DSU and GSU level. These assemblies will not be stocked above DS and GS level or returned to depot supply level.

(2) Maintenance code indicates the lowest category of maintenance authorized to install the listed item. The maintenance level codes are:

<u>Code</u>	<u>Explanation</u>
<u>C</u>	Operator/Crew
<u>O</u>	Organizational Maintenance
<u>F</u>	Direct Support Maintenance
<u>H</u>	General Support Maintenance
<u>D</u>	Depot Maintenance

(3) Recoverability code indicates whether unserviceable items should be returned for recovery or salvage. Items not coded are expendable. Recoverability codes are:

<u>Code</u>	<u>Explanation</u>
<u>R</u>	Repair parts and assemblies that are economically repairable at DSU and GSU activities and are normally furnished by supply on an exchange basis.
<u>S</u>	Repair parts and assemblies which are economically repairable at DSU and GSU activities and which normally are furnished by supply on an exchange basis. When items are determined by GSU to be uneconomically repairable, they will be evacuated to a depot for evaluation and analysis before final disposition.
<u>I</u>	High dollar value recoverable repair parts which are subject to special handling and are issued on an exchange basis. Such repair parts normally are repaired or overhauled at depot maintenance activities.
<u>U</u>	Repair parts specifically selected for salvage by reclamation units because of precious metal content, critical materials, or high dollar value reusable casings or castings.

b. Federal Stock Number. Indicates the Federal stock number assigned to the item and will be used for requisitioning purposes.

c. Description. Indicates the Federal item name and any additional description of the item required. A part number or other reference number is followed by the applicable five-digit Federal supply code for manufacturers in parentheses.

d. Unit of Measure (U/M). A two character alphabetic abbreviation indicating the amount or quantity of the item upon which the allowances are based, e. g., ft, ea, pr, etc.

e. Quantity Incorporated in Unit. Indicates the quantity of the item used in the assembly. Subsequent appearances of the same item in the same assembly are indicated by the letters "REF".

f. 15-Day Organizational Maintenance Allowances.

(1) The allowance columns are divided into four subcolumns. Indicated in each subcolumn opposite the first appearance of each item is the total quantity of items authorized for the number of equipments supported. Subsequent appearances of the same item will have the letters "REF" in the allowance columns. Items authorized for use as required, but not for initial stockage, are identified with an asterisk in the allowance column.

(2) The quantitative allowances for organizational level of maintenance represents one initial prescribed load for a 15-day period for the number of equipments supported. Units and organizations authorized additional prescribed loads will multiply the number of prescribed loads authorized by the quantity of repair parts reflected in the appropriate density column to obtain the total quantity of repair parts authorized.

(3) Organizational units providing maintenance for more than 100 of these equipments shall determine the total quantity of parts required by converting the equipment quantity to a decimal factor by placing a decimal point before the next to last digit of the number to indicate hundredths, and multiplying the decimal factor by the parts quantity authorized in the 51-100 allowance column. Example, authorized allowance for 51-100 equipments is 12; for 140 equipments multiply 12; by 1.40 or 16.80 rounded off to 17 parts required.

(4) Subsequent changes to allowances will be limited as follows: No change in the range of items is authorized. If additional items are considered necessary, recommendation should be forwarded to Commanding General, U. S. Army Electronics Command, ATTN: AMSEL-ME-NMP-EM, Fort Monmouth, New Jersey 07703, for exception or revision to the allowance list. Revisions to the range of items authorized will be made by the USA ECOM National Maintenance Point based upon engineering experience, demand data, or TAERS information,

g. 30-Day DS/GS Maintenance Allowances.

Note: Allowances in GS Column are for GS maintenance only.

(1) The allowance columns are divided into three subcolumns. Indicated in each subcolumn, opposite the first appearance of each item, is the total quantity of items authorized for the number of equipments supported. Subsequent appearances of the same item will have the letters "REF" in the applicable allowance columns. Items authorized for use as required, but not for initial stockage, are identified with an asterisk in the allowance column.

(2) The quantitative allowances for DS/GS levels of maintenance will represent initial stockage for a 30-day period for the number of equipments supported.

(3) Determination of the total quantity of parts required for maintenance of more than 100 of these equipments can be accomplished by converting the equipment quantity to a decimal factor by placing a decimal point before the next to last digit of the number to indicate hundredths, and multiplying the decimal factor by the parts quantity authorized in the 51-100 allowance column. Example, authorized allowance for 51-100 equipments is 40; for 150 equipments multiply 4 by 1. 50 or 60 parts required.

h. 1-Year Allowances Per 100 Equipments/Contingency Planning Purposes. Indicates opposite the first appearance of each item the total quantity required for distribution and contingency planning purposes. The range of items indicates total quantities for all authorized items required to provide for adequate support of 100 equipments for one year. Subsequent appearances of the same item will have the letters "REF" in the allowance column. Items authorized for use as required, but not for initial stockage, are identified with an asterisk in the allowance column.

i. Depot Maintenance Allowance Per 100 Equipments. Indicates opposite the first appearance of each item the total quantity authorized for depot maintenance of 100 equipments. Subsequent appearances of the same item will have the letters "REF" in the allowance column. Items authorized for use as required, but not for initial stockage, are identified with an asterisk in the allowance column

j. Illustrations.

(1) Figure number. Indicates the figure number of the illustration in which the item is shown.

(2) Item number or reference designation. Indicates the reference designation used to identify the item in the illustration.

D1-4. Special Information.

a. Repair parts mortality is computed from failure rates derived from experience factors with the individual parts in a variety of equipments. Variations in the specific application and periods of use of electronics equipment, the fragility of electronic piece parts, plus intangible material and quality factors intrinsic to the manufacture of electronic parts, do not permit mortality to be based on hours of end item use. However, long periods of continuous use under adverse conditions are likely to increase repair parts mortality.

b. Parts which require manufacture or assembly at a category higher than that authorized for installation will indicate in the source column the higher category.

D1-5. Location of Repair Parts.

a. This manual contains two cross reference indexes (sect. VII and sect. VIII) to be used to locate a repair part when either the Federal stock number, reference number (manufacturer's part number), or reference designation is known. The first column in the index is prepared in numerical and/or alphanumeric sequence in ascending order.

Where a Federal stock number is not listed, refer to the reference number (manufacturer's part numbers) immediately following the Federal stock numbers.

b. When the Federal stock number is known, follow the procedures given in (1) and (2) below.

(1) Refer to the index of Federal stock numbers (sect. VII) and locate the Federal stock number. The FSN is cross-referenced to the applicable figure and reference designation.

(2) When the reference designation is determined, refer to the reference designation index (sect. VIII). The reference designations are listed in alphanumeric ascending order and are cross referenced to the page number on which they appear in the repair parts list (sect. III and/or sect. V). Refer to the page number noted in the index and locate the reference designation in the repair parts list (col. 7b, Repair Parts for Organizational Maintenance or col. 10b, Repair Parts for Direct Support, General Support, and Depot Maintenance). If the word "REF" appears in the allowance column for the repair part, note the Federal stock number (col. 2) or manufacturer's part number (col. 3). Refer to the FSN index and note the reference designation for that FSN or part number. Refer to the reference designation index and note the page number given for the reference designation. Refer to the page noted in the RPSTL (sect. m or sect. V) and locate the reference designation in column 7b, Repair Parts for Organizational Maintenance or column 10b, Repair Parts for Direct Support, General Support, and Depot Maintenance of the repair parts list.

c. When the reference designation is known, follow the procedures given in b(2) above.

d. When neither the FSN nor reference designation is known, identify the part in the illustration and follow directions given in c above, or scrutinize column 3 of the repair parts lists (sect. HI and sect. V).

D1-6. Federal Supply Code for Manufacturers.

<u>Code</u>	<u>Manufacturer</u>
56878	Standard Pressed Steel Company P.O. Box 796, Jenkintown, Pa. 19046
77870	The Rochester Corporation Brandy Road, Culpeper, Va. 22701
80063	Army Electronics Command Procurement and Production Directorate Ft. Monmouth, N.J. 07703
88044	Aeronautical Standards Group Department of Navy and Air Force
96906	Military Standards Promulgated by Standardization Division Directorate of Logistic Services DSA

SECTION II. PRESCRIBED LOAD ALLOWANCE

(1) FEDERAL STOCK NUMBER	(2) DESCRIPTION	USABLE ON CODE	(3) 15-DAY ORG. MAINT. ALLOWANCE			
			(a) 1-5	(b) 6-20	(c) 21-50	(d) 51-100
53400407-2814	CLW, ASSEMBLY SMD5598T5 (80063)				2	2
5975-403-1011	GUY SMD561910 (80063)					2
3975-973-1032	GUY SMC561651 (80063)				2	2
5340-422-2116	HANGER ASSEMBLY SMC559889 (80063)				2	2
5985-954-4940	WAVEGUIDE ASSEMBLY CG-330T/GRC				2	2
5985-954-4939	WAVEGUIDE ASSEMBLY CG-3251/GRC					2

SECTION III. REPAIR PARTS FOR ORGANIZATIONAL MAINTENANCE

(1) SMR CODE	(2) FEDERAL STOCK NUMBER	(3) DESCRIPTION REFERENCE NUMBER & MFR CODE USABLE ON CODE		(4) UNIT OF MEAS	(5) QTY INC IN UNIT	(6) 15-DAY ORGANIZATIONAL				(7) ILLUSTRATION	
						(a)	(b)	(c)	(d)	(a) FIGURE NO.	(b) ITEM NO. OR REFERENCE DESIGNATION
						1-5	6-20	21-50	51-100		
G C S	5985-926-2593	ANTENNA AS-1425/GRC									
P C	5985-477-8335	ADAPTER SMC561779-1 (80063)		ea	1	*	*	*	*	1-1 ①	MP1
P C	5340-407-2814	CLAMP, ASSEMBLY SMD559875 (80063)		ea	8	*	*	2	2	1-1 ②	MP2
P C	5340-407-2814	CLAMP, ASSEMBLY SMD559875 (80063)		ea	REF	REF	REF	REF	REF	1-1 ②	MP3
P C	5340-407-2814	CLAMP, ASSEMBLY SMD559875 (80063)		ea	REF	REF	REF	REF	REF	1-1 ②	MP4
P C	5340-407-2814	CLAMP, ASSEMBLY SMD5598T5 (80063)		ea	REF	REF	REF	REF	REF	1-1 ②	MP5
P C	5340-407-2814	CLAMP, ASSEMBLY SMD559875 (80063)		ea	REF	REF	REF	REF	REF	1-1 ②	MP6
P C	5340-407-2814	CLAMP, ASSEMBLY SMD559875 (80063)		ea	REF	REF	REF	REF	REF	1-1 ②	MP7
P C	5340-407-2814	CLAMP, ASSMPLY SMD559875 (80063)		ea	REF	REF	REF	REF	REF	1-1 ②	HP8
P C	5340-407-2814	CLAMP, ASSEMBLY SMD559875 (80063)		ea	REF	REF	REF	REF	REF	1-1 ②	MP9
P C	5975-403-1012	GUY SMD561910 (80063)		ea	1	*	*	*	2	1-1 ②	A1
P C	5975-403-1012	GUY SMC561651 (80063)		ea	4	*	*	2	2	1-1 ①	A2
P C	5975-403-1012	GUY SMC561651 (80063)		ea	REF	REF	REF	REF	REF	1-1 ①	A3
P C	5975-403-1012	GUY SMC561651 (80063)		ea	REF	REF	REF	REF	REF	1-1 ①	A4
P C	5975-403-1012	GUY SMC561651 (80063)		ea	REF	REF	REF	REF	REF	1-1 ①	A5
P C	5985-413-4418	FRAME, ASSEMBLY SMD561727 (80063)		ea	1	*	*	*	*	1-1 ①	A7
P C S	5985168-424	HORN, ASSEMBLY SME561641 (80063)		ea	1	*	*	*	*	1-1 ①	A6
P C	5985-117-2900	HOUSING, ASSEMBLY SMD561642 (80063)		e	1	*	*	*	*	1-1 ①	A8
P C U	5985-477-8334	REFLECTOR ASSEMBLY SMD561729 (80063)		ea	1	*	*	*	*	1-1 ①	A9
P C	5340-422-2116	HANGER ASSEMBLY SMC559889 (80063)		ea	15	*	*	2	2	1-1 ②	MP1, MP16-P29
P C	5985-954-4946	WAVEGUIDE ASSEMBLY CG-3250/GRC		ea	1	*	*	*	*	1-1 ②	MP12
P C	5985-954-4940	WAVEGUIDE ASSEMBLY CG-3307/GRC		ea	6	*	*	2	2		MP13, MP30-MP34
P C	5985-954-4939	WAVEGUIDE ASSEMBLY CG-3251/GRC		ea	2	*	*	*	2	1-1 ②	MP14, MP15

SECTION V REPAIR PARTS FOR DIRECT SUPPORT, GENERAL SUPPORT, AND DEPOT MAINTENANCE

(1) SMR CODE	(2) FEDERAL STOCK NUMBER	(3) DESCRIPTION REF. NUMBER & MFR CODE USABLE ON CODE	(4) UNIT OF MEAS	(5) QTY INC IN UNIT	(6) 30-DAY DS MAINT ALLOWANCE			(7) 30-DAY GS MAINT ALLOWANCE			(8) 1-YR ALW PER 100 EQUIP CNTGCT	(9) DEPOT MAINT ALW PER 100 EQUIP	(10) ILLUSTRATION	
					(a)	(b)	(c)	(a)	(b)	(c)			(a)	(b)
					1-20	21-50	51-100	1-20	21-50	51-100			FIG NO.	ITEM NO. OR REFERENCE DESTINATION
G C S	5985-926-2593	ANTENNA AS-1425/GRC												
P C	5985-477-8335	ADAPTER, ANTENNA SMC561779-1 (80063)	ea	1	*	*	2	*	*	*	8	8	1-1①	MP1
P C	5340-407-2814	CLAMP, ASSEMBLY SMD559875 (80063)7	ea	8	*	2	2	*	2	2	28	80	1-1②	MP2
P C	5340-407-2814	CLAMP, ASSEMBLY SMD559875 (80063)7	ea	REF	REF	REF	REF	REF	REF	REF	REF	REF	1-1②	MP3
P C	5340-407-2814	CLAMP, ASSEMBLY SMD559875 (80063)	ea	REF	REF	REF	REF	REF	REF	REF	REF	REF	1-1②	MP4
P C	5340-407-2814	CLAMP, ASSEMBLY SMD559875 (80063)7	ea	REF	REF	REF	REF	REF	REF	REF	REF	REF	1-1②	MP5
P C	5340-407-2814	CLAMP, ASSEMBLY SMD559875 (80063)	ea	REF	REF	REF	REF	REF	REF	REF	REF	REF	1-1②	MP6
P C	5340-407-2814	CLAMP, ASSEMBLY SMD559875 (80063)	ea	REF	REF	REF	REF	REF	REF	REF	REF	REF	1-1②	MP7
P C	5340-407-2B14	CLAMP, ASSEMBLY SMD559875 (80063)	ea	REF	REF	REF	REF	REF	REF	REF	REF	REF	1-1②	MP8
P C	5340-407-2814	CLAMP, ASSEMBLY SMD559875 (80063)	ea	REF	REF	REF	REF	REF	REF	REF	REF	REF	1-1②	MP9
P C	5975-403-1011	GUY SMD561910 (80063)	ea	1	*	*	2	*	*	2	12	10	1-1②	A1
X 2 F		SNAP, HOOK SMB561726-1 (80063)	ea	1										A1MP2
X 2 F		SNAP, HOOK SMB561752-1 (80063)	ea	1										A1MP3
X 2 F		SLEEVE, SWAGING SMB561905-1 (80063)	ea	3										A1MP4
X 2 F		SLEEVE, SWAGING SMB561905-1 (80063)	ea	REF										A1MP5
X 2 F		SLEEVE, SWAGING SMB561905-1 (80063)	ea	REF										A1MP6
X 2 F		THIMBLE ROPE SMB561906-4 (80063)	ea	3										A1MP7
X 2 F		THIMBLE ROPE SMD561906-4 (80063)	ea	REF										A1MP8
X 2 F		THIMBLE ROPE SMD561906-4 (80063)	ea	REF										A1MP9
X 2 F		TENSIONER, CABLE SME561775-2 (80063)	ea	1										A1MP10
X 2 F		WIRE, ROPE, STEEL 7X19-1-8DIA (77870)	ea	1										A1MP1
P C	5975-403-1012	GUY SMC561651 (80063)	ea	1	*	2	2	*	*	2	28	40	1-1①	A2
X 2 F		SNAP, HOOK SMB561726-1 (80063)	ea	1										A2MP2
X 2 F		SNAP, HOOK SMD561726-1 (80063)	ea	1										A2MP3
X 2 F		SLEEVE, SWAGING SMB561905-1 (80063)	ea	3										A2HP4
X 2 F		SLEEVE, SWAGING SMB561905-1 (80063)	ea	REF										A2MP5
X 2 F		SLEEVE, SWAGING SMB561905-1 (80063)	ea	REF										A2MP6
X 2 F		THIMBLE ROPE SMB561906-4 (80063)	ea	3										A2MP7
X 2 F		THIMBLE ROPE SMB561906-4 (80063)	ea	REF										A2MP8

**SECTION V REPAIR PARTS FOR DIRECT SUPPORT, GENERAL SUPPORT, AND DEPOT MAINTENANCE
(CONTINUED)**

(1) SMR CODE	(2) FEDERAL STOCK NUMBER	(3) DESCRIPTION REF. NUMBER & MFR CODE USABLE ON CODE		(4) UNIT OF MEAS	(5) QTY INC IN UNIT	(6) 30-DAY DS MAINT ALLOWANCE			(7) 30-DAY GS MAINT ALLOWANCE			(8) 1-YR ALW PER 100 EQUIP CNTGCT	(9) DEPOT MAINT ALW PER 100 EQUIP	(10) ILLUSTRATION	
						(a)	(b)	(c)	(a)	(b)	(c)			(a)	(b)
						1-20	21-50	51-100	1-20	21-50	51-100			FIG NO.	ITEM NO. OR REFERENCE DESTINATION
X 2 F		THIMBLE ROPE SMB561906-4 (80063)	ea	REF											A2MP9
X 2 F		TENSIONER, CABLE SME561775-2 (80063)	ea	1											A2MP10
X 2 F		WIRE, ROPE, STEEL 7X19-1-8DIA (77870)	ea	1											A2MP11
P C	5975-403-1012	GUY SMD561910 (80063)	ea	1	REF	REF	REF	REF	REF	REF	REF	REF	REF	1-1 ①	A3
X 2 F		SNAP, HOOK SMB561726-1 (80063)	ea	1											A3MP1
X 2 F		SNAP, HOOK SMB561726-1 (80063)	ea	1											A3MP2
X 2 F		SLEEVE, SWAGING SMB561905-1 (80063)	ea	3											A3MP3
X 2 F		SLEEVE, SWAGING SMB561905-1 (80063)	ea	REF											A3MP4
X 2 F		SLEEVE, SWAGING SMB561905-1 (80063)	ea	REF											A3MP5
X 2 F		THIMBLE ROPE SMB561906-4 (80063)	ea	3											A3MP6
X 2 F		THIMBLE ROPE SMB561906-4 (80063)	ea	REF											A3MP7
X 2 F		THIMBLE ROPE SMB561906-4 (80063)	ea	REF											A3MP8
X 2 F		TENSIONER, CABLE SME561775-2 (80063)	ea	1											A3MP9
X 2 F		WIRE, ROPE, STEEL 7X19-1-8DIA (77870)	ea	1											A3MP10
P C	5975-403-1012	GUY SMC561651 (80063)	ea	1	REF	REF	REF	REF	REF	REF	REF	REF	REF	1-1 ①	A4
X 2 F		SNAP, HOOK SMB561726-1 (80063)	ea	1											A4MP1
X 2 F		SNAP, HOOK SMB561726-1 (80063)	ea	1											A4MP2
X 2 F		SLEEVE, SWAGING SMB561905-1 (80063)	ea	3											A4MP3
X 2 F		SLEEVE, SWAGING SMB561905-1 (80063)	ea	REF											A4MP4
X 2 F		SLEEVE, SWAGING SMB561905-1 (80063)	ea	REF											A4MP5
X 2 F		THIMBLE ROPE SMB561906-4 (80063)	ea	3											A4MP6
X 2 F		THIMBLE ROPE SMB561906-4 (80063)	ea	REF											A4MP7
X 2 F		THIMBLE ROPE SMB561906-4 (80063)	ea	REF											A4MP8
X 2 F		TENSIONER, CABLE SME561775-2 (80063)	ea	1											A4MP9
X 2 F		WIRE, ROPE, STEEL 7X19-1-8DIA (77870)	ea	1											AMP10
P C	5975-403-1012	GUY SMC561651 (80063)7	ea	REF	REF	REF	REF	REF	REF	REF	REF	REF	REF	1-1 ①	A5
X		SNAP, HOOK SMB561726-1 (80063)	ea	1											A5MP1
X 2 F		SNAP, HOOK SMB561726-1 (80063)	ea	1											A5MP2

**SECTION V REPAIR PARTS FOR DIRECT SUPPORT, GENERAL SUPPORT, AND DEPOT MAINTENANCE
(CONTINUED)**

(1) SMR CODE	(2) FEDERAL STOCK NUMBER	(3) DESCRIPTION REF. NUMBER & MFR CODE USABLE ON CODE		(4) UNIT OF MEAS	(5) QTY INC IN UNIT	(6) 30-DAY DS MAINT ALLOWANCE			(7) 30-DAY GS MAINT ALLOWANCE			(8) 1-YR ALW PER 100 EQUIP CNTGCT	(9) DEPOT MAINT ALW PER 100 EQUIP	(10) ILLUSTRATION		
						(a)	(b)	(c)	(a)	(b)	(c)			(a) FIG NO.	(b) ITEM NO. OR REFERENCE DESTINATION	
						1-20	21-50	51-100	1-20	21-50	51-100					
X 2 F		SLEEVE, SWAGING SMB561905-1 (80063)		ea	3											A5MP3
X 2 F		SLEEVE, SWAGING SMB561905-1 (80063)		ea												A5MP4
X 2 F		SLEEVE, SWAGING SMB561905-1 (80063)		ea												A5MP5
X 2 F		THIMBLE ROPE SMB561906-4 (80063)		ea	3											A5MP6
X 2 F		THIMBLE ROPE SMB561906-4 (80063)		ea	REF											A5MP7
X 2 F		THIMBLE ROPE SMB561906-4 (80063)		ea	REF											A5MP8
X 2 F		TENSIONER, CABLE SME561775-2 (80063)		ea	1											A5MP9
X 2 F		WIRE, ROPE, STEEL 7X19-1-8DIA (77870)		ea	1											A5MP10
P C	5985-413-4418	FRAME, ASSEMBLY SMD561727 (80063)		ea	1	*	*	*	*	*	*	8	4	1-1①		A7
X 2 F		BOLT ASSEMBLY SMB561646 (80036)		ea	2											A7H2
X 2 F	5310-974-6623	WASHER, SPLIT MS35338-140 (96906)		ea	2											A7H2
X 2 F		BOLT ASSEMBLY SMB561646 (80036)		ea	2									2-5		A7H2
X 2 F		NUT, SELF LOCK 50FAF616 (56878)		ea	2											A7H2
X 2 F		BUSHING, SLEEVE SMB561754-1 (80063)		ea	2											A7MP1
X 2 F		BUSHING, SLEEVE SMB561754-1 (80063)		ea	REF											A7MP2
X 2 F		EYEBOLT SMB561773 (80063)		ea	1											A7MP3
X 2 F		NUT, PLAIN, SQUARE SMB561773-2 (80063)		ea	1											A7MP3H1
X 2 F	5310-974-6623	WASHER, SPLIT MS35338-140 (96906)		ea	1											A7MP3H1
X 2 F		EYEBOLT SMB561773 (80063)		ea	1											A7MP4
X 2 F		NUT, PLAIN, SQUARE SMB561773-2 (80063)		ea	1											A7MP4H1
X 2 F	5310-974-6623	WASHER, SPLIT MS35338-140 (96906)		ea	1											A7MP4H1
P C S	5985-168-4274	HORN, ASSEMBLY SME561641 (80063)		ea	1	*	*	*	*	*	*	4	2	1-1①		A6
P F	5340-286-8718	RING, RETAINING MS16633-4037 (96906)		ea	4	*	*	*	*	*	*	10	8			A6H4
P F		THUMBSCREW SMB561647 (80063)		ea	4	*	*	*	*	*	*	10	8	2-7		A6H4
X 2 F	5310-974-6623	WASHER, SPLIT MS35338-140 (96906)		ea	4											A6HR
P F		CLAMP ASSEMBLY SMC561738-1 (80063)		ea	1	*	*	*	*	*	*	5	5			A6MP1
X 2 F	5310-934-9751	NUT, PLAIN MS35650-302 (96906)		ea	6											A6MP1H6
X 2 F		SCREW, MACHINE SMC561738-2 (80063)		ea	6											A6MP1H6

**SECTION V REPAIR PARTS FOR DIRECT SUPPORT, GENERAL SUPPORT, AND DEPOT MAINTENANCE
(CONTINUED)**

(1) SMR CODE	(2) FEDERAL STOCK NUMBER	(3) DESCRIPTION REF. NUMBER & MFR CODE USABLE ON CODE		(4) UNIT OF MEAS	(5) QTY INC IN UNIT	(6) 30-DAY DS MAINT ALLOWANCE			(7) 30-DAY GS MAINT ALLOWANCE			(8) 1-YR ALW PER 100 EQUIP CNTGCV	(9) DEPOT MAINT ALW PER 100 EQUIP	(10) ILLUSTRATION	
						(a)	(b)	(c)	(a)	(b)	(c)			(a)	(b)
						1-20	21-50	51-100	1-20	21-50	51-100			FIG NO.	ITEM NO. OR REFERENCE DESTINATION
X 2 F	5310-045-3296	WASHER, SPLIT MS35338-43 (96906)	ea	6											A6MP1H6
X 2 F		COVER, PLATE SMC561777-1 (80063)	ea	1											A6MP2
P F	5330-809-3816	PACKING, PREFORMED MS90064-16 (96906)	ea	1	*	*	*	*	*	*	5	4			A6MP3
P F		THUMBSCREW SMB561751-1 (80063)	ea	1	*	*	*	*	*	*	4	2			A6MP3H1
P F		THUMBSCREW SMB561751-2 (80063)	ea	1	*	*	*	*	*	*	4	2			A6MP3H1
X 2 F	5310-167-0812	WASHER, FLAT AN960C102 (88044)	ea	3											A6MP3H3
X 2 F		FRAME, IRIS SMD561764-1 (80063)	ea	1											A6MP6
X 2 F		GASKET SME561761-1 (80063)	ea	1											A6MP5
X 2 F		IRIS, WAVEGUIDE SMB561762-1 (80063)	ea	1											A6MP4
X 2 F	5305-054-5651	SCREW, MACHNIE MS51957-17 (96906)	ea	9											A6MP6H9
X 2 F	5310-982-5000	NUT, SELF, LOCKING, HEXAGON MS21045C4 (96906)	ea	10											A6MP3H10
X 2 F	5305-054-5652	SCREW, MACHINE MS51957-18 (96906)	ea	1											A6MP6H1
P F	5935-081-1233	CONNECTOR, RECEPTACLE, ELECTRICAL MS3100R16-10P (96906)	ea	1	*	*	*	*	*	*	8	5	2-7		A6J1
X 2 F	5310-982-5000	NUT, SELF, LOCKING, HEXAGON MS21045C04 (96906)	ea	4											A6J1H4
X 2 F	5305-054-5652	SCREW, MACHINE MS51957-18 (96906)	ea	4											A6J1H4
P F	5935-T55-3493	CONNECTOR, PLUG, ELECTRICAL MS3106R16-10S (96906)	ea	1	*	*	*	*	*	*	8	5	4-1		A6P1
P F		COVER ELECTRICAL, CONNECTOR MS25048-16C (96906)	ea	1	*	*	*	*	*	*	5	2	2-7		A6MP7
P F		HEATER, ASSEMBLY SMC561731 (80063)	ea	1	*	*	*	*	*	*	8	4	4-1		A6A1
X 1 F		HEATER SMC561739-1 (80063)	ea	1									4-1		A6A1HR1
X 1 F		TUBE SMC561793-1 (80063)	ea	1									4-1		A6A1MP1
X 1 F		WIRE, ELECTRICAL SMB561783-1 (80063)	ft	1									4-1		A6A1W1
X 2 F		TAPE, ELECTRICAL SMB561724-1 (80063)	ea	AR									4-1		A6MP8
X 2 F		TAPE, ELECTRICAL SMB561725-1 (80063)	ea	AR									4-1		A6MP9
M D		WIRE, ROPE ASSEMBLY SMB561732 (80063)	ea	1											A6A2
X 2 F		HOOKS SMB561784-2 (80063)	ea	1											A6A2H1
X 2 F		SCREW, DRIVE SMB561718-2 (80063)	ea	1											A6A2H1
X 2 F		SLEEVE SWAGING SMB561794-1 (80063)	ea	2											A6A2MP1
X 2 F		SLEEVE SWAGING SMB561794-1- (80063)	ea	REF											A6A2MP2

**SECTION V REPAIR PARTS FOR DIRECT SUPPORT, GENERAL SUPPORT, AND DEPOT MAINTENANCE
(CONTINUED)**

(1) SMR CODE	(2) FEDERAL STOCK NUMBER	(3) DESCRIPTION REF. NUMBER & MFR CODE USABLE ON CODE		(4) UNIT OF MEAS	(5) QTY INC IN UNIT	(6) 30-DAY DS MAINT ALLOWANCE			(7) 30-DAY GS MAINT ALLOWANCE			(8) 1-YR ALW PER 100 EQUIP CNTGCV	(9) DEPOT MAINT ALW PER 100 EQUIP	(10) ILLUSTRATION	
						(a)	(b)	(c)	(a)	(b)	(c)			(a)	(b)
						1-20	21-50	51-100	1-20	21-50	51-100			FIG NO.	ITEM NO. OR REFERENCE DESTINATION
X 2 F			WIRE, ROPE, STEEL 1X7-031DIA (77870)	ea	1										A6A2MP3
P C	5985-117-2900		HOUSING ASSEMBLY SMD561642 (80063)	ea	1	*	*	*	*	*	*	8	4	1-1①	A8
X 2 F			BOLT, ASSEMBLY SMB561646 (80063)	ea	1									2-4	A8H1
X 2 F	5310-974-6623		WASHER, SPLIT SM35338-140 (96906)	ea	1										A8H1
X 2 F			BUSHING, SLEEVE SMB561792-1 (80063)	ea	1										A8H1
X 2 F	5305-103-2072		SCREW, CAP, HEXAGON, READ MS35307-419 (96906)	ea	1									2-6	A8H1
X 2 F	5310-167-0806		WASHER FLAT AN960C816 (88044)	ea	1										A8H1
X 2 F	5310-933-8778		WASHER SPLIT MS35338-143 (96906)	ea	1										A8H1
X 2 F			BLOCK, ASSEMBLY SMD561728 (80063)	ea	1									5-1	A8A1
X 2 F			BLOCK, MOUNTING SMD561728-1	ea	1									5-1	A8A1MP1
X 2 F	5340-825-4826		INSERT SCREW MS21208C0620 (96906)	ea	4									5-1	A8A1H4
X 2 F	5340-814-9865		INSERT SCREW MS21209C8-15 (96906)	ea	1									5-1	A8A1H1
X 2 F	5340-290-4519		INSERT SCREW MS21208C6-10 (90906)	ea	2									5-1	A8A1H2
X 2 F			BOOT, DUST AND MOISTURE PROOF SMB561760-1 (80063)	ea	1									5-1	A8MP2
X 2 F			BUSHING, SLEEVE SMB561753-1 (80063)	ea	1									5-1	A8M3
X 2 F			PLATE, MOUNTING SMB561T49-1 (80063)	ea	1									5-1	A8MP4
X 2 F	5305-054-6670		SCREW, MACHINE MS5195T-45 (96906)	ea	4									5-1	A8MP3K4
X 2 F			SCREW, MACHINE AX515C8-8 (88044)	ea	4									5-1	AMP3K4
X 2 F			SPACER, SLEEVE SMB561797-1 (80063)	ea	1									5-1	A8MP3H
X 2 F	5313-933-8119		WASHER, SPLIT MS35333-13T (96906)	ea	8									5-1	A8MP3H8
X 2 F			SLEEVE SMB561786-1 (80063)	ea	2									5-1	A8MP5
x 2 F			BUSHING SLEEVE SMIB56T6-i (80063)	ea	REF									5-1	A8Me6
X 2 F			BUSHING, SLEEVE SMB561759-1 (80063)	ea	2									5-1	A8MPT
X 2 F			BUSHING, SLEEVE SMB5617T59- (80063)	ea	REF									5-1	A8MP8
X 2 F			HOSE SMB56i719-3 (80063)	ea	1									5-1	A8MP9
X 2 F			CAM, HOSE SMn56i719-4 (80063)	ea	1									51	A8MP10
X 2 F			CAN 8MB561766-1 (80063)	ea	1									S1	A8MP11
X 2 F	5305-579-4624		SCREW, MACHINE AN5315C6-8 (88044)	ea	4									5-1	A8MP11H4

**SECTION V REPAIR PARTS FOR DIRECT SUPPORT, GENERAL SUPPORT, AND DEPOT MAINTENANCE
(CONTINUED)**

(1) SMR CODE	(2) FEDERAL STOCK NUMBER	(3) DESCRIPTION REF. NUMBER & MFR CODE USABLE ON CODE	(4) UNIT OF MEAS	(5) QTY INC IN UNIT	(6) 30-DAY DS MAINT ALLOWANCE			(7) 30-DAY GS MAINT ALLOWANCE			(8) 1-YR ALW PER 100 EQUIP CNTGCTY	(9) DEPOT MAINT ALW PER 100 EQUIP	(10) ILLUSTRATION	
					(a)	(b)	(c)	(a)	(b)	(c)			(a)	(b)
					1-20	21-50	51-100	1-20	21-50	51-100			FIG NO.	ITEM NO. OR REFERENCE DESTINATION
X 2 F	5310-638-9857	WASNER, FLAT AH960C6L (88o44)	ea	4									5-1	A8A1MP11H4
X 2 F	5310-929-6395	WASHER, SPLTT MS35338-136 (96906)	ea	4									5-1	A8A1MP11H4
X 2 F		COVER, PULLEY SMD5617441 (80063)	ea	1									5-1	A8A1MP12
X 2 F		SCREW, MACHINE AU515CA-8 (88044)	ea	7									5-1	A8A1MP12H7
X 2 F	5310-933-8119	WASHER, SPLIT MS35338-73T (96906)	ea	7									5-1	A8A1MP127
X 2 F		COVER SMB1561790 (80063)	ea	1									5-1	A8A1MP13
X 2 F		PLATE, SCALE SMB561774-1 (80063)	ea	1									5-1	A8A1MP14
X 2 F	5310-982-5000	NUT, SELFLOCKING HEXAGON MS21045CO4 (96906)	ea	2									5-1	A8A1P14H2
X 2 F	5305-054-5649	SCREW, MACHINE MS5195T-15 (96906)	ea	2									5-1	A8MP14H2
X 2 F	5310-638-9857	WASHER, FLAT A960C6L (88i3044)	ea	2									5-1	A8MP14H2
X 2 F		PULLEY, GROOVE SMC561T34 (80063)	ea	1									5-1	A8MP15
X 2 F	5305-068-5404	SCREW, CAP, HEXAGON HEAD MS16996-14 (96906)	ea	4									5-1	A8MP15H4
X 2 F	5305-203-1429	SCREW, CAP, HEXAGON HEAD MS3530T-363 (96906)	ea	2									5-1	A8MP15H2
X 2 F	5310-773-7618	WASHER, FLAT M815795-814 (96906)	ea	2									5-1	A8MP15H2
X 2 F	5310-933-8120	WASHER, SPILT MS35338-138 (96906)	ea	2									5-1	A8MP15H2
X 2 F		ROD, ASSEMBLY SM13561733 (80063)	ea	1									5-1	A8A2
X 2 F		NUT, PLAIN, ROUND SMC561780i (80063)	ea	1									5-1	A8A2H1
X 2 F	5315-143-6284	PIN, SPRING MS171534 (96906)	ea	1									5-1	ASA2H1
X 2 F		WASHER, NONMETALLIC SMB56iT57-1 (80063)	ea	1									5-1	A8A2H1
X 2 F		CAP, ROD SMC561748-1 (80063)	ea	1									5-1	A8A2MP1
X 2 F		ROD, STEEL SM3561789-1 (80063)	ea	1									5-1	A8A2MP2
X 2 F	5340-290-4519	IIINSERT SCREW MS21208C6-10(96906)	ea	1									5-1	A8A2MP1H1
X 2 F		PIN, SPRING MST171656 (96906)	ea	1									5-1	A8A2MP2H1
X 2 F		TUBE, PLASTIC SMB561791-1(80063)	ea	1									5-1	A8MP16
X 2 F		PLATE, IDENTIFICATION SMD558718-10-(80063)	ea	1										MP10
X 2 F	5305-054-5647	SCREW MACHINE MS51957-13 (96906)	ea	4										MP1OH4
X 2 F	5310-042-9609	WASHER, SPILT MS35338-7 (96906)	ea	4										MP1OH4
P C U	5985-477-8334	REFLECTOR, ASSEMBLY SMD5L729 (80063)	ea	1	*	*	*	*	*	*	8	4	1-1①	A9

**SECTION V REPAIR PARTS FOR DIRECT SUPPORT, GENERAL SUPPORT, AND DEPOT MAINTENANCE
(CONTINUED)**

(1) SMR CODE	(2) FEDERAL STOCK NUMBER	(3) DESCRIPTION REF. NUMBER & MFR CODE USABLE ON CODE		(4) UNIT OF MEAS	(5) QTY INC IN UNIT	(6) 30-DAY DS MAINT ALLOWANCE			(7) 30-DAY GS MAINT ALLOWANCE			(8) 1-YR ALW PER 100 EQUIP CNTGCT	(9) DEPOT MAINT ALW PER 100 EQUIP	(10) ILLUSTRATION	
						(a)	(b)	(c)	(a)	(b)	(c)			(a) FIG NO.	(b) ITEM NO. OR REFERENCE DESTINATION
						1-20	21-50	51-100	1-20	21-50	51-100				
X 2 F		BRACKET MOUNTING SMC561750-1 (80063)		ea	1										A9MP1
X 2 F	5310-285-5635	NUT, SELF LOCKING HEXAGON AN363C420 (88044)		ea	1										A9MPH1
X 2 F		NUT, SELF LOCKING HEXAGON 50FAF518 (56878)		ea	2										A9MPIT2
X 2 F	5305-702-4523	SCREW, CAP,HEXAGON HEAD MS35307-306 (96906)		ea	1										A9MPIH1
X 2 F		SCREW, MACHINE AN526C518-12 (88044)		ea	2										A9M1P1H2
X 2 F	5310-531-9515	WASHER FLAT AN96oc416 (88o44)		ea	1										A9MP1H1
X 2 F		BRACKET, MOUNTING SMC561T50-1 (80063)		ea	1										A9M2
X 2 F	5310-285-5635	NUT, SELF LOCKING HEXAGON AN363C420(88044)		ea	1										A9MP2H1
X 2 F		NUT, SELF LOCKING HEXAGON 50FAF518(56878)		ea	2										A9MP2H2
X 2 F	5305-7022-4523	SCREW, CAP, HEXAGON MS35307-306 (96906)		ea	1										A9MP2H1
X 2 F		SCREW, MACHINE AN526518-12 (88o44)		ea	2										A9MP2H2
X 2 F	5310-531-9515	WASHER, FLAT AN969C416(880844)		ea	1										A9MP2H1
X 2 F		REFLECTOR ANTENNA SMC561740-1 (80063)		ea	1										A9MP3
X 2 F		RING ASSEMBLY SMD56143 (80063)		ea	1										A9MP4
X 2 F P		NUT SELF LOCKING 50FAF518 (568T7)		ea	6										A9MP4H6
X 2 F		SCREW, MACHINE AN526C518-12 (88o4)		ea	6										A9MPH46
X 2 F		RING, RETAINING SMC561736 (80063)		ea	1										A9MP5
X 2 F		RING RETAINING SMC561778-1(80063)		ea	1										A9MP6
X 2 F		SCREW MACHINE AN515C416(88044)		ea	4										A9MP6H4
X 2 F	5310-933-8121	WASHER, SPLIT MS35338-139 (96906)		ea	4										A9MP6R4
P C	5340-422-2116	HANGER ASSEMBLY SM559889 (80063)		ea 1	15	*	2	2	*	2	2	27	30	1-1Ⓢ	MP11,MP16MP29
P C	5985-954-4946	WAVE ASSEMBLYCG-3250/GHC		ea	*1*	*	*	*	*	*	*	8	4	1-1Ⓢ	MP12
P C	5985-954-40	WAVE ASSEMBLY CG-3307/GRC		ea	6	*	2	2	*	2	2	2	30	12	MP13,MP30NP34
P C	5985-95139	WAVE ASSEMBLY CG-3251/GRC		ea	2	*	*	2	*	*	*	13	4	1-1Ⓢ	MP14,MP15

SECTION VII INDEX-FEDERAL STOCK NUMBER CROSS REFERENCE

TO FIGURE AND ITEM NUMBER OR REFERENCE DESIGNATION

FEDERAL STOCK NUMBER	FIGURE NUMBER	ITEM NUMBER OR REF. DESIGNATION	FEDERAL STOCK NUMBER	FIGURE NUMBER	ITEM NUMBER OR REF. DESIGNATION
5305-054-5647	-	MP10H4	5340-407-2814	1-1 ②	MP2
5305-055-6491	5-1	A8MP14H2		1-1 ②	MP3
5305-054-5651	-	A6MP6H9		1-1 ②	MP4
3305-054-5652	-	A6J1H4		1-1 ②	MP5
	-	A6MP6HH		1-1 ②	MP7
5305-054-6670	5-1	A8MP3H4		1-1 ②	MP8
5305-068-5405	5-1	A8M115H4		1-1 ②	MP9
5305-103-2072	2-6	A8H1	5340-422-2116	1-1 ②	MP11
5305-208-1429	5-1	A8MP15H2		1-1 ②	MP16
5305-579-4624	5-1	A8MP11H4		1-1 ②	MP17
5305-702-4523	-	A9MP1H1		1-1 ②	MP18
	-	A9MP2H1		1-1 ②	MP20
5310-042-9609	-	MP10H4		1-1 ②	MP22
5310-045-3296	-	A6MP1H6		1-1 ②	MP23
5310-167-0806	-	A8H1		1-1 ②	MP24
5310-167-0812	-	A6MP3H3		1-1 ②	MP25
5310-285-5635	-	A9HP1H1		1-1 ②	MP26
	-	A9MP2H1		1-1 ②	MP28
5310-531-9515	-	A9MP1H1		1-1 ②	MP28
	-	A9MP2H1		1-1 ②	MP29
5310-638-9857	5-1	A8A1MP11H4	5340-814-9865	5-1	A8A1H1
	5-1	A8MP14H2	5340-825-4826	5-1	A8A1H4
5310-773-7618	5-1	A8M15H2	5935-081-1233	2-7	A6J1
5310-929-6395	5-1	A8A1MP11H4	5935-755-3493	4-1	A6P1
5310-933-8119	5-1	A8A1MP12H7	5975-403-1031	1-1 ②	A1
	5-1	A8MP3H8	5975-403-1012	1-1 ①	A2
5310-933-8120	5-1	A8MP15H2		1-1 ①	A3
5331-933-8121	-	A9MP6H4		1-1 ①	A4
5310-933-8778	-	A8H1		1-1 ①	A5
5310-934-9751	-	A6MP1H6	5985-117-2900	1-1 ①	A8
5310-974-6623	2-5	A7H2	5985-168-4274	1-1 ①	A6
	-	A8H1	5985-413-4418	1-1 ①	A7
5310-982-5000	-	A6J1H4	5985-477-8334	1-1 ①	A9
	-	A6MP3H10	5985-477-8335	1-1 ①	MP1
	5-1	A8A1MP14H2	5985-954-4939	1-1 ②	MP14
5310-984-7042	-	A6H4		1-1 ②	MP15
	-	A7MP3H1	5985-954-4940	1-1 ②	MP13
	-	A7MP4H1		1-1 ②	MP30
5315-143-6284	5-1	A8A2H1		1-1 ②	MP31
5330-809-3816	-	A6MP3		1-1 ②	MP32
5350-286-8718	-	A6H4		1-1 ②	MP33
5340-290-4519	5-1	A8A1H2		1-1 ②	MP31
	5-1	A8A2MP1H1	5985-954-4946	1-1 ②	MP12

SECTION VII INDEX-FEDERAL STOCK NUMBER CROSS REFERENCE

TO FIGURE AND ITEM NUMBER OR REFERENCE DESIGNATION (CONTINUED)

REFERENCE NO.	MFR. CODE	FIG. NO.	ITEM NUMBER OR REF. DESIGNATION NUMBER	REFERENCE NO.	MFR. CODE	FIG. NO.	ITEM NO. OR REF. DESIGNATION
AN363C420	88044	-	A9MP1H1	MS51957-15	96906	5-1	A8MP14H2
		-	A9MP2H1	MS51957-17	96906	-	A6MP6H9
AN515C416-14	88044	-	A9MP6H4	MS51957-8	96906	-	A6J1H4
AN515C6-8	88044	5-1	A8MP11H4			-	A6MP6H1
AN515C8-8	88044	5-1	A8A1MP12H7	MS51957-45	96906	5-1	A8MP3H4
		5-1	A8MP3H4	MS90064-16	96906	.	A6MP3
AN526C518-12	88044	-	A9MP3H2	SMB561644	80063	-	A7H2
		-	A9NP2H2	SMB561646	80063	-	A7H2
		-	A9MP4H6			2-4	A8H1
AN960C102	88044	-	A6MP3H3	SMB561647	80063	2-7	A6H4
AN960C416	88044	-	A9MP1H1	SMB561718-2	80063	-	A6A2H1
		-	A9MP2H1	SMB561719-3	80063	5-1	A8MP9
AN960C6L	88044	5-1	A8A1MP11H4	SMB561719-4	80063	5-1	A8MP10
		5-1	A8MP14H2	SMB561724-1	80063	4-1	A6MP8
AN960C816	88044	-	A8H1	SMB563725-1	80063	4-1	A6MP9
MS15795-814	96906	5-1	ABMP15H2	SMB561726-1	80063	-	A1MP2
MS16633-4037	96906	-	A6H4			-	A2MP2
MS16996-14	96906	5-1	A8MP15H4			-	A3MP1
MS171534	96906	5-1	A8A2H1			-	A4MP1
MS171656	96906	5-1	A8A2MP2H1			-	A5MP1
MS21045C04	96906	-	A6J1H4	SMB561732	80063	-	A6A2
		-	A6MP3H10	SMB561733	80063	5-1	A8A2
		5-1	A8A1MP14H2	SMB561719-1	80063	5-1	ARMP4
MS21208C0620	96906	5-1	A8A1H4	SMB563751-1	80063	-	A3MP3H1
MS21208C6-10	96906	5-1	A8A1H2	SMB561751-2	80063	-	A6MP3H1
		5-1	A8A2MP1H1	SMB561752-1	80063	-	A1MP3
MS21209C8-15	96906	5-1	A8A1H1			-	A2MP3
MS25048-16C	96906	2-7	A6MP7			-	A3MP2
MS3100R16-10P	96906	2-7	A6J1			-	A4MP2
MS3106R16-10S	96906	4-1	A6P1			-	A5MP2
MS35307-363	96906	5-1	A8MP15H2	SMB1753-1	80063	5-1	A8MP3
MS35307-306	96906	-	A9MP1H1	SMB561754-1	80063	-	A7MP1
		-	A9MP2H1			-	A7MP2
MS35307-419	96906	2-6	A8H1	SMB561757-1	80063	5-1	A8A2H1
MB35338-136	96906	5-1	A8A1MP11H4	SMB561759-1	80063	5-1	A8MP7
MS35338-137	96906	5-1	A8A1MP12H7			5-1	A8MP8
		5-1	A8MP3H8	SMB561760-1	80063	5-1	A8MP2
MS35338-138	96906	5-1	A8MP15H2	SMB561761-1	80063	-	A6MP5
MS35338-139	96906	-	A9MP6H4	SMB561762-1	80063	-	A6MP6
MS35338-110	96906	2-5	A7H2	SMB561766-1	80063	5-1	A8MP11
		-	A8H1	SMB561773	80063	-	A7MP3
MB35338-141	96906	-	A6H4			-	A7MP4
		-	A7MP3H1	SMB561773-2	80063	-	A7MP3H1
		-	A7MP4H1			-	A7MP4H1
M35338-143	96906	-	A8H1	SMB561774-1	80063	5-1	A8A1MP14
M35338-43	96906	-	A6MP1H6	SMB561783-1	80063	4-1	A6A1W1
MB35338-78	96906	-	MP10H4	SMB561784-2	80063	-	A6A2H1
MB35650-102	96906	-	A6MP1H6	SMB563786-1	80063	5-1	A8MP5
MS51957-13	96906	-	MP10H4			5-1	A8MP6

**SECTION VII INDEX-FEDERAL STOCK NUMBER CROSS REFERENCE
TO FIGURE AND ITEM NUMBER OR REFERENCE DESIGNATION (CONTINUED)**

REFERENCE NO.	MFR. CODE	FIG. NO.	ITEM NUMBER OR REF. DESIGNATION NUMBER	REFERENCE NO.	MFR. CODE	FIG. NO.	ITEM NUMBER OR REF. DESIGNATION
SMB561789-1	80063	5-1	A8A2MP2	SMC561738-2	80063	-	A6MP1H6
SMB561790	80063	5-1	A8A1MP13	SMC561739-1	80063	4-3	A6A1HR1
SMB561791-1	80063	5-1	A8MP16	SMC561740-1	80063	-	A9MP3
SMB561792-1	80063	-	A8H1	SMC561748-1	80063	5-1	A8A2MP1
SMB561794-1	80063	-	A6A2MP1	SMC561750-1	80063	-	A9MP1
			A6A2MP2				A9MP2
SMB561797-1	80063	5-1	A8MP3H1	SMC561777-1	80063	-	A6MP2
SMB561905-1	80063	-	A1MP4	SMC561778-1	80063	-	A9MP6
		-	A1MP5	SMC561779-1	80063	1-1 ①	MP1
		-	A1MP6	SMC561780-1	80063	5-1	A8A2H1
		-	A2MP4	SMC561793-1	80063	4-1	A6A1MP1
		-	A2MP5	SMD558718-10	80063	-	MP10
		-	A2MP6	SMD559875	80063	1-1 ②	MP2
		-	A3MP3			1-1 ②	MP3
		-	A3MP4			1-1 ②	MP4
		-	A3MP5			1-1 ②	MP5
		-	A4MP3			1-1 ②	MP6
		-	A4MP4			1-1 ②	MP7
		-	A4MP5			1-1 ②	MP8
		-	A5MP3			1-1 ②	MP9
		-	A5MP4	SMD561642	80063	1-1 ①	A8
		-	A5MP6	SMD561643	80063	-	A9MP4
SMB561906-4	80063	-	A1MP7	SMD561727	80063	1-1 ①	A7
		-	A1MP8	SMD561728	80063	5-1	A8A1
		-	A2MP7	SMD561728-1	80063	5-1	A8A1MP1
		-	A2MP8	SMD561729	80063	1-1 ①	A9
		-	A3MP6	SMD561744-1	80063	5-1	A8A1MP12
		-	A3MP7	SMD561764-1	80063	-	A6MP4
		-	A3MP8	SMD561910	80063	1-1 ②	A1
		-	A4MP6	SME561641	80063	1-1 ①	A6
		-	A4MP7	SME561775-2	80063	-	A1MP10
		-	A4MP8			-	A2MP10
		-	A5MP6			-	A3MP9
		-	A5MP7			-	A4MP9
		-	A5MP8			-	A5MP9
SMC559889	80063	1-1 ②	MP11	1X7-031DIA	77870	-	A6A2MP3
		1-1 ②	MP16	50FAF518	56878	-	A9MP1H2
		1-1 ②	MP17			-	A9MP2H2
		1-1 ②	MP18			-	A9MP4H6
		1-1 ②	MP19	50FAF616	56878	-	A7H2
		1-1 ②	MP20	7X19-1-8DIA	77870	-	A1MP1
		1-1 ②	MP21			-	A2MP1
		1-1 ②	MP22			-	A3MP10
		1-1 ②	MP23			-	A4MP10
		1-1 ②	MP24			-	A5MP10
		1-1 ②	MP25				
		1-1 ②	MP26				
		1-1 ②	MP27				
		1-1 ②	MP28				
		1-1 ②	MP29				
SMC561651	80063	1-1 ①	A2				
		1-1 ①	A1				
		1-1 ①	A3				
		1-1 ①	A4				
SMC561731	80063	4-1	A5				
SMC561734	80063	5-1	A8MP15				
SMC561736	80063	-	A9MP5				
SMC561738-1	80063	-	A6MP1				

**SECTION VIII INDEX-REFERENCE DESIGNATION
CROSS REFERENCE TO PAGE NUMBER**

REFERENCE DESIGNATION	PAGE NUMBER	REFERENCE DESIGNATION	PAGE NUMBER	REFERENCE DESIGNATION	PAGE NUMBER	REFERENCE DESIGNATION	PAGE NUMBER
A1	D-5, D-6	A4MP9	D-6.3	A7H2	D-6.2	A8MP16	D-6.5
A1MP1	D-6	A4MP10	D-6.1	A7MP1	D-6.2	A9	D-5, D-6.5
A1MP2	D-6	A5	D-5, D-6.1	A7MP2	D-6.2	A9MP1	D-6.6
A1MP3	D-6	A5MP1	D-6.1	A7MP3	D-6.2	A9MP1H1	D-6.6
A1MP4	D-6	A5MP2	D 6.1	A7MP3H1	D-6.2	A9MP1H2	D-6.6
A1MP5	D-6	A5MP3	D-6.2	A7MP4	D-6.2	A9MP2	D-6.6
A1MP6	D-6	A5MP4	D-6.2	A7MP4H1	D-6.2	A9MP2H1	D-6.6
A1MP7	D-6	A5MP5	D-6.2	A8	D-5, D-6.4	A9MP2H2	D-6.6
A1MP8	D-6	A5MP6	D-6.2	A8A1	D-6.4	A9MP3	D-6.6
A1MP9	D-6	A5MP7	D-6.2	A8A1H1	D-6.4	A9MP4	D-6.6
A1MP10	D-6	A5MP8	D-6.2	A8A1H2	D-6.4	A9MP4H6	D-6.6
A2	D-5, D-6	A5MP9	D-6.2	A8A1H4	D-6.4	A9MP5	D-6.6
A2MP1	D-6.1	A5AMP10	D-6.2	A8A1MP1	D-6.4	A9MP6	D 6.6
A2MP2	D-6	A6	D-5, D-6.2	A8A1MP11H4	D-6.5	A9MP6H4	D-6.6
A2MP3	D-6	A6A1	D-6.2	A8A1MP12	D-6.5	MP1	D-5, D-6
A2MP4	D-6	A6A1HR1	D-6.3	A8A1MP12H7	D-6.5	MP2	D-5, D-6
A2MP5	D-6	A6A1MP1	D-6.3	A8A1MP13	D-6.4	MP3	D-5, D-6
A2MP6	D-6	A6A1W1	D-6.3	A8A1MP143	D-6.5	MP4	D-5, D-6
A2MP7	D-6	A6A2	D-6.3	A8A1MP14H2	D-6.5	MP5	D-5, D-6
A2MP8	D-6	A6A2H1	D-6.3	A8A2	D-6.5	MP6	D-5, D-6
A2MP9	D-6.1	A6A2H1	D-6.3	A8A2H1	D-6.5	MP7	D-5, D-6
A2MP10	D-6.1	A6A2MP1	D-6.3	A8A2MP1	D-6.5	MP8	D-5, D-6
A3	D-5, D-6.1	A6A2MP2	D-6.3	A8A2MP1H1	D-6.5	MP9	D-5, D-6
A3MP1	D-6.1	A6A2MP3	D-6.4	A8A2MP2	D-6.5	MP10	D-6.5
A3MP2	D-6.1	A6H4	D-6.2	A8A2MP2H1	D-6.5	MP10H4	D-6.5
A3MP3	D-6.1	A6J1	D-6.3	A8H1	D-6.4	MP11	D-5, D-6.6
A3MP4	D-6.1	A6J1H4	D-6.3	A8MP2	D6.4	MP12	D-5, D-6.6
A3MP5	D-6.1	A6MP1	D-6.2	A8MP3	D6.4	MP13	D-5, D6.6
A3MP6	D-6.1	A6MP1H6	D-6.2, D-6.3	A8MP3H1	D-6.4	MP14	D-5, D-6.6
A3MP7	D-6.1	A6MP2	D-6.3	A8MP3H4	D6.	MP15	D-5, D-6.6
A3MP8	D-6.1	A6MP3	D-6.3	A8MP3H8	D6.4	MP16	D-5, D-6.6
A3MP9	D-6.1	A6MP3H1	D-6.3	A8MP4	6.4	MP29	D-6.6
A3MP10	D-6.1	A6MP3H3	D-6.3	A8MP5	D-6.4	MP30	D-5, D-6.6
A4	D-5, D-6.1	A6MP4	D-6.3	A8MP6	D-6.4	NP34	D-6.6
A4MP1	D-6.1	A6MP5	D-6.3	A8MP7	D6.4		
A4MP2	D-6.1	A6MP6	D-6.3	A8MP8	D_6.4		
A4MP3	D-6.1	A6MP6H1	D-6.3	A8MP9	D-6.4		
A4MP4	D-6.1	A6MP6H10	D-6.3	A8MP10	D-6.4		
A4MP5	D-6.1	A6MP6H9	D-6.3	A8MP11	D_6.4		
A4MP6	D-6.1	A7MP7	D-6.3	A8MP11H4	6.4.k		
A4MP7	D-6.1	A6MP8	D-6.3	A8MP14H2	06.5		
A4MP8	D-6.1	A6MP9	D-6.3	A8MP15	D6.5		
		A6P1	D-6.-3	A8MP15H4	D6.5		
		A7	D-5				
			D-6.3				

INDEX

	<u>Paragraph</u>	<u>Page</u>
Analysis of operation.....	4-1	30
Antenna adjustment procedures	2-7	24.3
Applicability of depot overhaul standards.....	5-5	35
Checking unpacked equipment	2-2	16
Cleaning.....	3-6	29
Components of Antenna AS-1425/GRC	1-6	11
Description of Antenna AS-1425/GRC.....	1-7	11
Description of operating accessories.....	1-8	12
Destruction of army electronics materiel.....	1-3.4	10
Disassembly and reassembly of tilting assembly	5-4	34
Disassembly of equipment	6-1	41
Erection of antenna.....	2-6	17
Forms and records:		
Discrepancy in Shipment Report (DISREP) (SF 361).....	1-3c	7
Reporting equipment improvement recommendations (EIR).....	1-3.2	7
Reporting errors and recommending improvements.....	1-3.1	7
Report of packaging and handling deficiencies.....	1-3b	7
Reports of maintenance and unsatisfactory equipment	1-3a	7
General depot maintenance information	5-1	33
General maintenance instructions	4-2	30
General siting considerations	2-3	16
Index of Army publications and blank forms.....	1-2	7
Maintenance procedures, depot	5-2	33
Operation under unusual climatic conditions.....	2-8	25
Operator/Crew daily preventive maintenance checks and services chart	3-5	28

	<u>Paragraph</u>	<u>Page</u>
Operator/Crew preventive maintenance:	3-3	26
Preventive maintenance checks and services	3-4	27
Operator's troubleshooting	3-7	29
Organizational preventive maintenance checks and services	3-8	29
Organizational troubleshooting information	3-11	29
 Physical and deicer tests:		
Deicer test	5-7 <u>d</u>	39
Dimensional test	5-7 <u>c</u>	39
Structural test	5-7 <u>b</u>	38
Visual test	5-7 <u>a</u>	38
 Plotting profiles	2-4	17
Purpose and use	1-4	10
 Removal and replacement of deicer equipment	4-7	32
Removal and replacement of feedhorn.....	4- 5	31
Removal and replacement of feedhorn iris.....	4-6	31
Removal and replacement of reflector.....	5-3	33
Removal and replacement of tilting assembly	4-4	30
Repackaging for shipment or limited storage:		
Material requirements	6-2 <u>a</u>	41
Packaging.....	6-2 <u>c</u>	42
Wrapping.....	6-2 <u>b</u>	42
Replacement of components.....	4- 3	30
Reporting errors and recommending improvements	1-3.1	7
Reporting equipment improvement recommendations (EIR)	1-3.2	7
 Scope of manual	1-1	7
Scope of operator's maintenance	3-1	26
S storage of equipment	1-3.3	10
System applications	1- 9	12

	<u>Paragraph</u>	<u>Page</u>
Technical characteristics	1-5	10
Test equipment required for depot maintenance.....	5-6	38
Tools and test equipment required for installation.....	2-5	17
Tools, materials, and test equipment required for operator's maintenance.....	3-2	26
Touchup painting.....	3-12	29
Unpacking the equipment-		
Packaging data.....	2-1 <u>a</u>	14
Packing dimensions.....	2-1 <u>b</u>	14
Removing contents of wooden box	2-1 <u>c</u>	14
VSWR test:		
Test conditions.....	5-8a	39
Test procedure.....	5-8b	40

By Order of the Secretary of the Army:

Official:

KENNETH G. WICKHAM
*Major General, United States Army,
The Adjutant General.*

W. C. WESTMORELAND,
*General, United States Army
Chief of Staff*

DISTRIBUTION:

To be distributed in accordance with DA FORM 12-51, Organizational maintenance requirements for AN/GRC-66, AN/GRC-68, and AN/GRC-144 Radio Sets.

☆U.S GOVERNMENT PRINTING OFFICE: 1984 -446-214/18729

RECOMMENDED CHANGES TO EQUIPMENT TECHNICAL PUBLICATIONS



THEN...JOT DOWN THE
DOPE ABOUT IT ON THIS FORM.
CAREFULLY TEAR IT OUT, FOLD IT
AND DROP IT IN THE MAIL.

SOMETHING WRONG WITH PUBLICATION

FROM: (PRINT YOUR UNIT'S COMPLETE ADDRESS)

DATE SENT

PUBLICATION NUMBER

PUBLICATION DATE

PUBLICATION TITLE

BE EXACT PIN-POINT WHERE IT IS

PAGE
NO.

PARA-
GRAPH

FIGURE
NO.

TABLE
NO.

IN THIS SPACE, TELL WHAT IS WRONG
AND WHAT SHOULD BE DONE ABOUT IT.

TEAR ALONG PERFORATED LINE

PRINTED NAME, GRADE OR TITLE AND TELEPHONE NUMBER

SIGN HERE

